

# INSTALLATION GUIDE

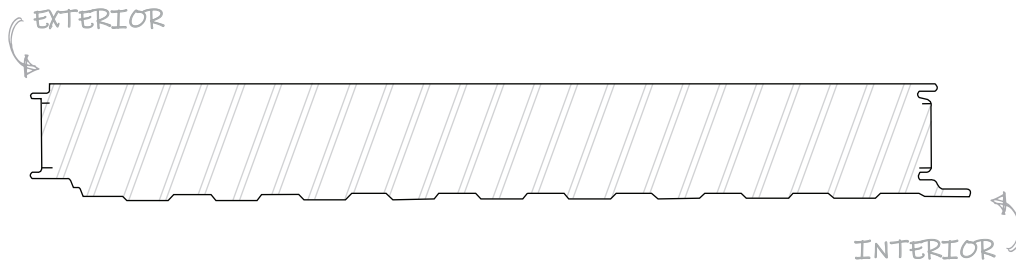

## RDEK ROOF PANEL RDEK - 40

FALK PANEL | INSTALLATION GUIDE RDEK - 40



### EVERYTHING YOU NEED TO KNOW ABOUT

raw materials, production, transportation and storage, installation, finishing, accessories, maintenance, usage, recycling and warranty.



## 2023 RDEK Installation Guide

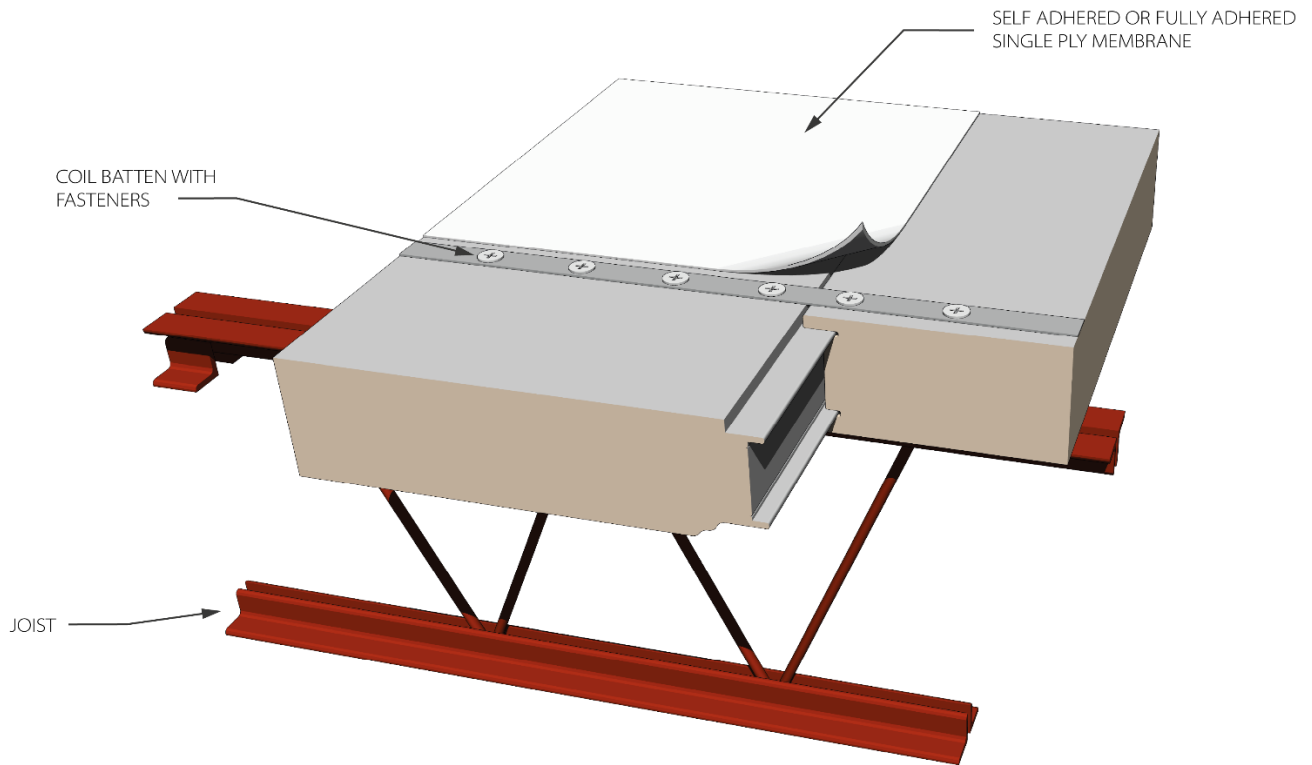

## TABLE OF CONTENTS

<b>NOTICE</b> .....	<b>4</b>
<b>PRODUCT DESCRIPTION</b> .....	<b>5</b>
<b>INTRODUCTION</b> .....	<b>6</b>
BACKGROUND .....	6
WHAT IS A SANDWICH PANEL? .....	6
THERMAL VALUES .....	6
<b>WARRANTIES</b> .....	<b>7</b>
PRODUCT GUARANTEE .....	7
GUARANTEE CONDITIONS .....	7
EXCLUSIONS .....	8
OTHER .....	9
<b>COATINGS</b> .....	<b>10</b>
Colorcoat HPS200 Ultra® Coatings .....	10
Sherwin-Williams Fluorpon 70% PVDF Coatings .....	10
Sherwin-Williams WeatherXL Siliconized Polyester Coatings .....	11
Sherwin-Williams Polyester Coating Guarantee .....	11
<b>INSTALLATION RECOMMENDATIONS</b> .....	<b>13</b>
Panel Inspection .....	13
Panel Handling & Safety .....	13
Protective Film .....	14
Removal of Protection Film .....	14
Covering .....	15
Storage Requirements .....	15
Unlimited Storage .....	16
Lifting Slings .....	16
Vacuum Lifter .....	17
Manual Carrying .....	17
Job Site Safety & Sealant Applications .....	18

Jobsite Sealant Applications .....	18
Roof Panel Installation Procedure .....	19
<b>RDEK40 PANEL INSTALLATION DETAILS .....</b>	<b>20</b>
Standard - 2", 6" O.C. Fastening Diaphragm.....	20
Standard - 2", 12" O.C. Fastening Diaphragm .....	21
Enhanced- 20" O.C. Fastening Diaphragm (Enhanced) .....	22
Enhanced - 2", 18" O.C. Fastening Diaphragm (Enhanced) .....	23
Standard RDEK Joint Detail .....	24
Enhanced RDEK Joint Detail .....	25
Intermediate Roof Fastening.....	26
Butt Joint Detail .....	27
Butt Joint Detail on Joist .....	28
Ridge Detail.....	29
Expansion Joint Details.....	30
Low Eave Detail (Gutter by Others) .....	31
Rake Detail W/ Rake Flashing .....	33
High Eave Detail W / High Eave Transition Trim.....	37
Parapet Cap W/ Metal Coping (At Low Side Eave) .....	40
Parapet Cap W/ Metal Coping (At Rake) .....	41
High Eave Detail W / Counter Flashing .....	43
Penetration At Roof Deck – Molded Pipe Boot .....	44
Penetration At Roof Deck – Molded Pipe Boot Single and Multi Pipe .....	45
Penetration At Roof Deck- Field Fabricated .....	46
Raised Perimeter Edge With Metal Flashing [Fascia Cap].....	47
Base Flashing at Expansion Joint With Metal Cover.....	48
Base Flashing at Lightweight Equipment Support Curb .....	48
Equipment Support Stand Leg [Premanufactured Split Pipe Flashing Boot] .....	49
Equipment Support Stand Leg [Field Wrap].....	49
Base Flashing at Sheet-metal Enclosure for Piping Through Roof Deck.....	50

Base Flashing at Stack Vent With Curb [Hot or Cold] .....	51
Sheet Metal Stack Vent [Hot or Cold] .....	51
Pipe Support.....	52
Cable Penetration .....	52
Lightning Protection Terminal .....	53
Roof Drain (Adhered Membrane Roof Systems) .....	53
Base Flashing at Through-wall Scupper .....	54
Open Web Joist Detail.....	55
Joist Edge Detail.....	56
Fully Adhered with Fastener Assembly - Joist .....	57
Fully Adhered with Batten Assembly.....	58
Self-Adhered with Fastener Assembly .....	59
<b>ACCESSORIES &amp; FASTENERS .....</b>	<b>60</b>
Accessories-1.....	61
Fasteners 1 .....	62
Fasteners 2.....	63
T-2 Selfdrill Roofscrew, LL Coating, PPH, #14 x 1-1/4" .....	64
<b>COMMON FLASHING PROFILES.....</b>	<b>65</b>
Flashings 1 .....	66
Flashings 2.....	67
Flashings 3.....	68
Flashings 4 .....	69



## NOTICE

THIS INSTALLATION GUIDE IS PROVIDED AS A REFERENCE TO THE DESIGN AND INSTALLATION COMMUNITY RELATIVE TO THE ACCEPTABLE TECHNIQUES PERMITTED BY FALK AS IT RELATES TO THE INSTALLATION OF HFW40 INSULATED METAL PANELS. DETAILS PROVIDED WITHIN THIS DOCUMENT ARE MINIMAL ACCEPTABLE GUIDELINES TO ENSURE APPROPRIATE INSTALLATION. ENHANCEMENTS TO DETAILS CONTAINED WITHIN THE DOCUMENT ARE PERMITTED PROVIDING FALK IS NOTIFIED IN ADVANCE AND ACCEPTS ENHANCEMENTS IN WRITING. IT IS THE RESPONSIBILITY OF THE INSTALLATION CONTRACTOR TO INSPECT ALL MATERIALS PRIOR TO INSTALLATION AND ANY DISCREPANCIES BETWEEN PROJECT ERECTION DRAWINGS, BILL OF MATERIALS, MATERIALS AND ACCESSORIES PROVIDED FOR A PROJECT MUST BE REPORTED TO FALK WITHIN 48 HOURS OF ACCEPTANCE OR DELIVERY. IF NON-CONFORMING PROJECT MATERIALS ARE PROVIDED TO A PROJECT, NEVER INSTALL THE MATERIALS WHILE ALSO REPORTING IT TO FALK.

**FALK PANEL LLC.** 1782 Northridge Dr. NW, Walker, MI 49544 USA

Tel: (616) 541 - 4500

E-mail: [info@FALKpanel.com](mailto:info@FALKpanel.com)

Website: [www.FALKpanel.com](http://www.FALKpanel.com)

**FALK PANELS CANADA LTD.** 11 Fulton Rd, Rocky View, AB T1X 0Z1, Canada

Tel: (587) 349 - 1777 E-mail:

[info@FALKpanels.ca](mailto:info@FALKpanels.ca) Website:

[www.FALKpanels.ca](http://www.FALKpanels.ca)

FALK's insulated metal panels are manufactured by FALK Production

## PRODUCT DESCRIPTION

FALK RDEK40

ROOF DECK PANEL FLAT ROOFING SYSTEMS FOR USE IN COMMERCIAL LOW SLOPE APPLICATIONS WITH THERMOPLASTIC ROOFING MEMBRANE.

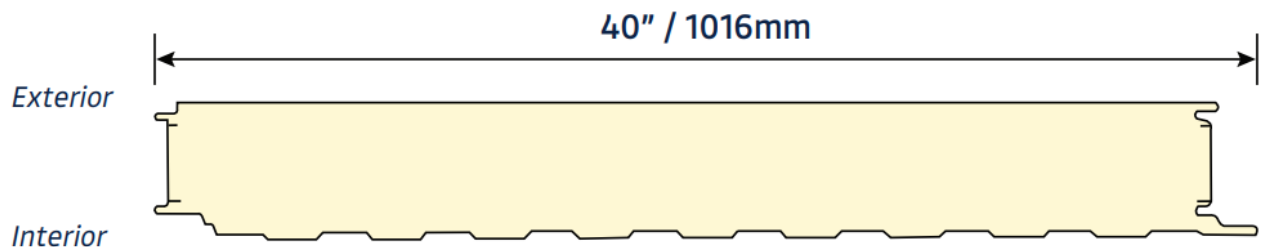

**Coverage Width**- 40"

**Panel Attachment** -- Roof Deck Pressure Plate w/ 2" Fasteners

**Exterior Panel Profile** - (Flat Smooth) Standard

**Exterior Panel Gauge** - 26, 24 & 22-Other gauges available (Please inquire)

**Interior Panel Finish** - (Box Profile and Flat Profile)

**Interior Panel Gauge** - 26 - Other gauges available (Please inquire)

**Coatings\*** - **Exterior:** PE / Dutch White (STD.)

**Interior:** PE / Dutch White (STD.) (Others on Requested)

**Panel Thickness** - 3", 4", 5" & 6" (FLAT ROOFING SYSTEM APPLICATION)

**Lengths** - Minimum: - 10'-0" to Maximum: 82'-0" \*\*

\* Refer to FALK Color Cards for standard and special color offerings

\*\* *Special Transportation Arrangements for Longer Lengths as Required*

## INTRODUCTION

### BACKGROUND

Progress and ambition. This is what sets FALK apart from the rest. Established in the Netherlands in 2007 by an elite team of installation contractors, FALK has assembled a dedicated team of professionals working hard to always put the customer wishes first while implementing methodologies to install insulated metal panels in an efficient, environmentally conscious manner. FALK Panel (referred to as FALK in this installation guide) has developed this installation guide to provide answers to frequently asked questions. Following you will find guidelines for transportation, storage, treatments, installation tips and tricks, and warranty options available for your next project. We realize that each project is tailor-made and that not all your questions will be answered in this manual. In case you require additional information, please contact our technical support department by phone at 616.541.4500 or email your question to [info@FALKpanel.com](mailto:info@FALKpanel.com). In addition to this, more information about our products, technical drawings and details can also be found at our website [WWW.FALKpanel.com](http://WWW.FALKpanel.com)

### WHAT IS A SANDWICH PANEL?

Sandwich panels (aka Insulated Metal Panels or IMP) are innovative building materials that bring design and functionality together. These panels provide an excellent solution to rapidly cover and insulate building projects. A sandwich panel consists of a profiled inner sheet and outer sheet, both made from high-quality steel and a core insulating material called polyisocyanurate foam (PIR). PIR is one of the most efficient insulation materials used in construction. PIR insulation provides acoustic and thermal properties, rigidity, durability, and excellent compressive strength. The adhesion between this insulation and sheets gives a sandwich panel (compared to a profiled sheet) additional firmness which permits larger spans to be reached. Sandwich panels are gaining in popularity in North America, since they are a high-quality, safe and easy to use product.

### THERMAL VALUES

HFW-40 Hidden Fixed Wall Panels are available in the following configurations:

RDEK-40 Specifications						
Core Thickness	Width	Steel Gauge		Thermal Values		Weight
in   mm	in   mm	Exterior	Interior	R-Values	U-Values	lbs/sf
2.5   63.5	40   1016	22ga, 24ga, 26ga	26ga	18.99	0.053	2.46
3.0   76.2	40   1016	22ga, 24ga, 26ga	26ga	22.79	0.043	2.63
4.0   101.6	40   1016	22ga, 24ga, 26ga	26ga	30.38	0.032	2.79
5.0   127	40   1016	22ga, 24ga, 26ga	26ga	37.98	0.026	2.95
6.0   152.4	40   1016	22ga, 24ga, 26ga	26ga	45.46	0.021	3.11

*Nominal 7.5 per inch with lambda ( $\lambda$ [W/mK]) of 0.019*





FALK RDEK40-Roof Deck Panels offer the building designer R values of approximately 7.50 per inch Nominal, as well as the ability to balance initial cost versus long-term energy savings. FALK also offers a full line of accessories to include attachment clips, metal trims, matching flat stock.

## WARRANTIES

FALK can furnish various performance warranties as required for your project. The items covered by these warranties include weather tightness, corrosion, structural performance, and finish performance. Weather tight warranties require the use of FALK's Authorized Installers. In addition, these projects may require jobsite inspections throughout the installation process. Warranty charges vary, so please contact your FALK representative for more information. FALK requires that all specifications and shop drawings are reviewed prior to warranty issuance.

Note: warranties are limited to materials supplied by FALK and are not issued until full payment for all services and material provided is received.

## PRODUCT GUARANTEE

FALK offers a guarantee of two years from the date of delivery for each panel and parts affixed thereto (the "Panel") it produces and supplies to the above customer or original owner of the Panel if different than the customer. This guarantee covers the following functional features: Product insulation, dimensional stability, and material quality. FALK does not offer a guarantee or warranty on interior finishes or non-supplied attachments to the Panel. This certificate of guarantee is nontransferable and shall be for the sole benefit of the original customer or owner who purchases the Panel from FALK. This written guarantee represents the full, complete, and final agreement of the parties and supersedes all prior guarantees or agreements relating to guarantees, or related negotiations between the parties. This guarantee cannot be modified, altered, or extended without the express written consent, signed by a duly authorized officer or employee of FALK. Disclaimer of implied guarantees and warranties. EXCEPT FOR THE EXPRESS GUARANTEES SET FORTH HEREIN, FALK MAKES NO GUARANTEE OR WARRANTY WHATSOEVER REGARDING THE PANELS, INCLUDING ANY (1) WARRANTY OF MERCHANTABILITY; OR (2) WARRANTY OF FITNESS FOR A PARTICULAR PURPOSE; WHETHER ARISING BY LAW, COURSE OF DEALING, COURSE OF PERFORMANCE, USAGE OF TRADE OR OTHERWISE. Additional guarantees and warranties are available for paint and coating systems in addition to the guarantee provided for herein. Contact your sales representative for further information. The information in this document is effective when provided to the customer or owner of the panel. Because FALK products and policies may improve or change in the future, FALK reserves the right to make modifications to this guarantee without notice. Important note, the sales conditions as well as this certificate of guarantee have been drawn up in the English language.

## GUARANTEE CONDITIONS

- Guarantees applies to panels erected solely in the continental United States, Alaska, and Canada. This guarantee specifically excludes Hawaii and Mexico and any other Country not identified above.
- Handling, storage, technical details, and installation must be carried out in accordance with FALK LLC instructions. These instructions are available on request. The guarantee provided for herein does not apply to Panels installed improperly and not in compliance with the FALK instructions, Panels

subjected to abuse, misuse, neglect, negligence, accident, improper installation, improper storage, improper handling, abnormal physical stress, abnormal environmental conditions or use contrary to the instructions issued FALK.

- It is the responsibility of the Building Owner to maintain the building and Panels affixed thereto in good order, and to prevent damage by equipment, intentional damage, negligence, or waste.
- Accumulated dirt and grim should be washed off the Panels at regular intervals. FALK recommends yearly. Continuous long-term ponding of water, continuous emersion or waterlogging damaging the Panel will void the guarantee provided for herein.
- Any defects must be reported to FALK in writing within 30 days of discovery.
- Dimensions, tolerances, and other relevant items for the Panels follow the ATSM standards.
- In case of a legitimate and justified claim, FALK, in its sole discretion shall determine whether the Panel is to be repaired or replaced. The choice of materials to be used or working methods to repair or replace the Panel is the sole responsibility of FALK.
- Repair or replacement costs shall not exceed the original invoiced amount per square foot of the original Panel purchased by the customer or owner.
- If Panels need to be replaced, within the original warranty period, the replacement panel will come with a two-year warranty.
- If Panels need to be replaced because of product defects or damage, after two years from date of purchase, the warranty recipient shall be fully responsible for the replacement cost of the panel.
- The guarantee provided for herein is only valid after all invoices related to the supplied Panels are paid in full. In the event the customer or owner fails to pay for the Panels in full at the time invoiced, the guarantee provided for herein is void.

## **EXCLUSIONS**

- Damage to a panel due to mechanical or chemical exposure and elements, abnormal environmental conditions, hail, fire, war, riot, falling objects, vandalism, natural disaster, lightning, or any other unforeseen circumstances are excluded and void the guarantee provided for herein.
- Any damage to the Panels caused during storage, transport, or installation, is excluded.
- Damage to the Panels due to incorrect installation, handling, or treatment is excluded. Panels that are damaged or blistered by rain or water entering the uncovered cut ends are also excluded. Cut ends of all panels must be immediately protected from the elements by means of flashings or other waterproof barriers. • Damage to the Panels caused by Panels being installed in improperly ventilated areas, or in areas deemed inappropriate for insulated metal panel use by FALK are excluded.
- Any defects in the Panels caused by exposure to continuous high temperatures, other than heat due to solar radiation, are excluded from this guarantee. Continuous surface temperature exceeding 180 degrees Fahrenheit are not covered by this guarantee.
- If Panels with known defects are installed, the guarantee herein is null and void.

- If damaged Panels need to be replaced or repaired, FALK will only be held responsible for replacement or the repair cost of those Panels.
- FALK will not be responsible for replacing building accessories like skylights, electrical installations, solar panels, etc. in a building, if a Panel requires repair or replacement.
- Any damage attributed to Panels being altered without prior authorization from FALK is not covered by this guarantee. This includes, but is not limited to add-ons, fixtures, or utilities placed against or attached to the Panels, installation of signage, vents or other breaches or cutting of the Panel, including, address numbers, mailboxes, skylights, solar panels, HVAC units, plumbing vents, electrical service, or ventilators.
- This guarantee does not cover damage that results from projectile damage from lawn or snow removal equipment, falling objects, recreational activities or contact of Panels from material storage of any kind.
- Damage to a Panel due to corrosion is not covered by this guarantee. This includes corrosion caused by drainage, leaking or overflowing gutters and downspouts, leaks from roof top units or equipment, salt (marine) or atmospheric contaminants, unusual or harsh contaminants that are generated within the building, including moisture due to inadequate or improper ventilation. Even if contaminants are identified or in existence at the time of installation of the Panels, FALK shall be under no obligation by the terms of this guarantee and warranty.

## **OTHER**

- This guarantee is voided if any repair work to a Panel is carried out by a third-party contractor, without the prior written consent of FALK.
- The product owner acknowledges FALK is responsible for the execution of this guarantee.
- FALK is not responsible for any incidental or consequential damage or losses arising from the use or damage of a Panel or any claims arising under this guarantee.
- The exclusive remedy to the customer or owner of the Panel is to have FALK repair or replace a damaged panel under this guarantee.
- Oil canning and minor imperfections are not a valid reason for rejection or a claim under this guarantee.
- This guarantee does not cover damages or events where Panels have been removed from their original location and re-installed in a secondary location.

## COATINGS

### Colorcoat HPS200 Ultra<sup>®</sup> Coatings

FALK is pleased to offer the following Limited Warranty on our Colorcoat HPS200 Ultra<sup>®</sup> coatings. This Warranty applies if any of the following Warranty Conditions occurs during the time period specified in the attached Warranty Table in years: a. Color coat HPS200 Ultra<sup>®</sup> coating will provide resistance against perforation due to weathering for the period stated above from the date of erection. Tata Steel Colors will support the performance of Color coat HPS200 Ultra<sup>®</sup> pre-finished steel, profiled by FALK for the duration as outlined with the chart below. At the end of the period, for any single plane, i.e. one wall or one roof slope, not more than 5% or 100 square meters of paint surface, whichever is the lesser area, will be affected by corrosion.

Coating	Inland Beyond 1 mile from coastline		Coastal Within 1 mile of coastline	
	Walls	Roofs	Walls	Roofs
Signature Colors 47°N – 70°N	30	30	25	20
Signature Colors 37°N – 47°N	25	20	20	15
Signature Colors 37°S – 37°N	15	10	10	8
Classic & Matt Colors 47°N – 70°N	30	20	20	15
Classic & Matt Colors 37°N – 47°N	20	10	15	10

This Limited Warranty is valid for products used for roofing and sidewall coil applications only.

### Sherwin-Williams Fluorpon 70% PVDF Coatings

FALK is pleased to offer THE FOLLOWING Limited Warranty on our Fluorpon<sup>®</sup> coil coatings. 1. This Warranty applies if any of the following Warranty Conditions occurs during the time period specified in the attached Warranty Table: a. Fluorpon<sup>®</sup> exhibits cracking, flaking or peeling (loss of adhesion) to an extent that is apparent on ordinary outdoor visual observation. Minute fracturing, which may occur in proper fabrication of the building parts, is not a covered Warranty Condition. Failure due to substrate corrosion is not a covered Warranty Condition. b. Fluorpon<sup>®</sup> chalks in excess of ASTM D-4214 method A number 8 rating when properly maintained as described herein. c. Fluorpon<sup>®</sup> changes color more than five (5.0) Hunter delta-E units as determined by ASTM method D-2244. Color change shall be measured on an exposed painted surface that has been cleaned of surface soils and chalk, and the corresponding values measured on the original or unexposed painted surface. Color changes may not be uniform on surfaces that are not equally exposed to the sun and elements and Sherwin-Williams does not warrant that color changes will be uniform.

<b>Product</b>	<b>Product Film integrity Warranty (Section 1a) (Years From Date of Coating Application)</b>	<b>Standard Colors Color Change Warranty (Section 1c) (Years From Date of Installation of Coated Panels)</b>	<b>Chalking Warranty (Section 1b) (Years From Date of Installation of Coated Panels)</b>
Fluropon®	<b>35</b>	<b>30</b>	<b>30</b>
Fluropon® Extreme (Hardcoat)	<b>35</b>	<b>30</b>	<b>30</b>
Fluropon® Premiere (requires clear coat)	<b>20</b>	<b>20</b>	<b>20</b>
Fluropon® Classic (requires clear coat - Metallic)	<b>20</b>	<b>20</b>	<b>20</b>
Fluropon® Classic II (Mica)	<b>20</b>	<b>20</b>	<b>20</b>

This Limited Warranty is valid for products used for roofing and sidewall coil applications only.

### **Sherwin-Williams WeatherXL Siliconized Polyester Coatings**

FALK is pleased to offer the following Limited Warranty on our WeatherXL Siliconized Polyester coil coatings. 1. This Warranty applies if any of the following Warranty Conditions occurs: a. Within 40 years from the date of application of the paint, WeatherXL exhibits cracking, flaking, or peeling (loss of adhesion) to an extent that is apparent on ordinary outdoor visual observation. Minute fracturing, which may occur in proper fabrication of the building parts, is not a covered Warranty Condition. Failure due to substrate corrosion is not a covered Warranty Condition. b. Within 30 years from the date of installation of the panels, WeatherXL: i. Chalks in excess of ASTM D-4214 method A number six (6) rating on horizontally installed (roofing) panels and a number eight (8) rating on vertically installed (sidewall) panels, when properly maintained as described herein, and ii. Changes color more than seven (7.0) Hunter delta-E units on horizontally installed (roofing) panels and five (5.0) Hunter delta-E units on vertically installed (sidewall) panels as determined by ASTM method D-2244. Color change shall be measured on an exposed painted surface that has been cleaned of surface soils and chalk, and the corresponding values measured on the original or unexposed painted surface. Color changes may not be uniform on surfaces that are not equally exposed to the sun and elements and Sherwin-Williams does not warrant that color changes will be uniform.

### **Sherwin-Williams Polyester Coating Guarantee**

FALK is pleased to offer the following Limited Warranty on our Polyester coil coatings. 1. This Warranty applies if any of the following Warranty Conditions occurs: a. Within 20 years from the date of application of the paint, Polyester exhibits cracking, flaking or peeling (loss of adhesion) to an extent that is apparent on ordinary outdoor visual observation. Minute fracturing, which may occur in proper fabrication of the building parts, is not a covered Warranty Condition. Failure due to substrate corrosion is not a covered Warranty Condition. b. From the date of installation of the panels, Polyester: i. Chalks in excess of ASTM D-4214 method A number six (6) rating on horizontally installed (roofing) panels within five (5) years and a number eight (8) rating on vertically installed (sidewall) panels within ten (10) years, when properly maintained as described herein, and ii. Changes color more than seven (7.0) Hunter delta-E units on



horizontally installed (roofing) panels within five (5) years and five (5.0) Hunter delta-E units on vertically installed (sidewall) panels with ten (10) years as determined by ASTM method D-2244. Color change shall be measured on an exposed painted surface that has been cleaned of surface soils and chalk, and the corresponding values measured on the original or unexposed painted surface. Color changes may not be uniform on surfaces that are not equally exposed to the sun and elements and Sherwin-Williams does not warrant that color changes will be uniform.

Please contact FALK customer service or your area sales manager to request copies of the coating suppliers' warranty terms, conditions, limitations, and exclusions.

## INSTALLATION RECOMMENDATIONS

### Panel Inspection

It is critical that you inspect your panels for damage prior to unpacking. FALK IMP bundles will arrive at the project site with identifying placards summarizing your order and panel counts. If panels are missing or damaged while in the care of FALK's logistics team, please contact us immediately while also taking photos of the damaged panels while on the truck. While FALK makes every effort to mitigate and prevent shipping damages, we are not responsible for damages that occur following delivery, while in storage at the project site or when repositioned on-site. We recommend you open and inspect the delivered bundles while staging them appropriately across your construction site in to facilitate easy installation.

FALK recommends that our panels are installed under the direct supervision of an experienced sheet metal craftsman trained in the proper application of our products. To learn more about our Authorized Installer programs please contact FALK at 616.541.4500.

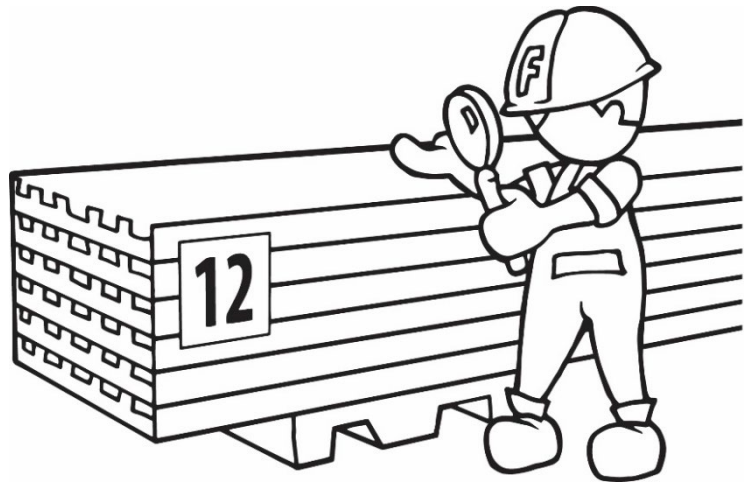

### Panel Handling & Safety

When hoisting sandwich panels be sure to check the maximum working load limit of the forklift or crane. The package that needs to be lifted may never exceed this weight. The package should always be prevented from falling. That is why it is important to select the most suitable hoisting equipment first. We advise you to use a vacuum lift, pallet lifter or lifting slings combined with a wooden or metal support system for hoisting packages of sandwich panels.

Please take caution while handling the RDEK40 Roof deck Panel improper unloading and handling of panel material bundles may cause bodily injury or material damage. FALK is not responsible for bodily injuries or damage during unloading and staging.

When using forklifts, make sure that forks are spread apart as far as possible. (5'-0" minimum)

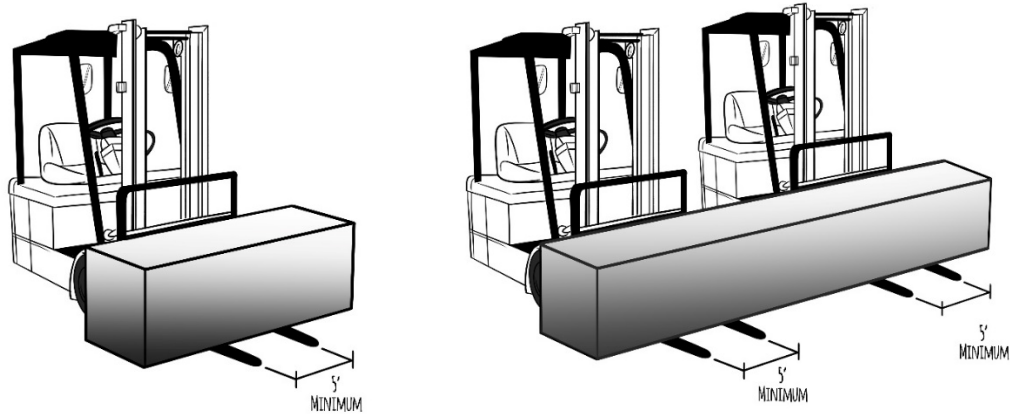

Handle with care and points of special attention.

- i. Be sure to avoid damaging panels on the opposite side of the struck when unloading.
- ii. Advance slowly and with caution once the bundle is on the forks.
- iii. Make sure to lift at the center of the bundle to avoid tipping.
- iv. Protective boards or foam should be placed on forklift load backrests to prevent damaging panel joints.

If two forklifts are required, unloading must be coordinated. Operators must work in unison to prevent damage.

### Protective Film

It is recommended to remove protective film as panels are installed. Film on installed panels should be removed by the end of each day. If panels are not installed within 60 days of receipt, the bundles should be unstacked, and the protective film removed from each panel. Carefully restack the panels while using foam slip sheets to protect the panels from damage. If adhesive residue remains on panel surfaces after the protective film is removed, panels may be cleaned with soapy water, WD-40, a cloth soaked in Oil-flo 141 or 409 cleaner.

### Removal of Protection Film

The protective film on the panels needs to be removed within four weeks after production. If this is not removed within this time frame the film may be difficult to remove.

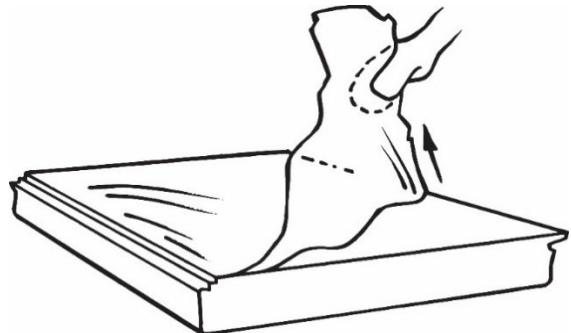



### Covering

You can protect the panels from exposure to direct sunlight, rain, or any dirt by using a breathable tarp (for example a canvas tarp). Fasten this tarp with anchors so it will not blow away. However, please do not attach the tarp directly to the package. Plastic tarps should not be used since they may cause condensation below the surface. In addition to this, always remove stagnant water between panels. Please note packages should be placed at a 4°-degree angle at least, so any moisture can flow away. Any shallow space below the Styrofoam pallets should also be filled so all pressure points are supported.

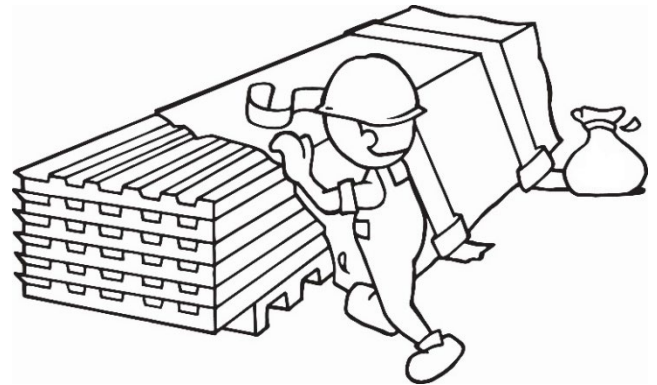

### Storage Requirements

We recommend stacking two packages on top of each other at the most. The longest package should be placed at the bottom. Please note: While stacking, the blocking and bracing needs to be clean and free from any other objects. This will limit the chance of irreparable damage to the top elements of the bottom package.

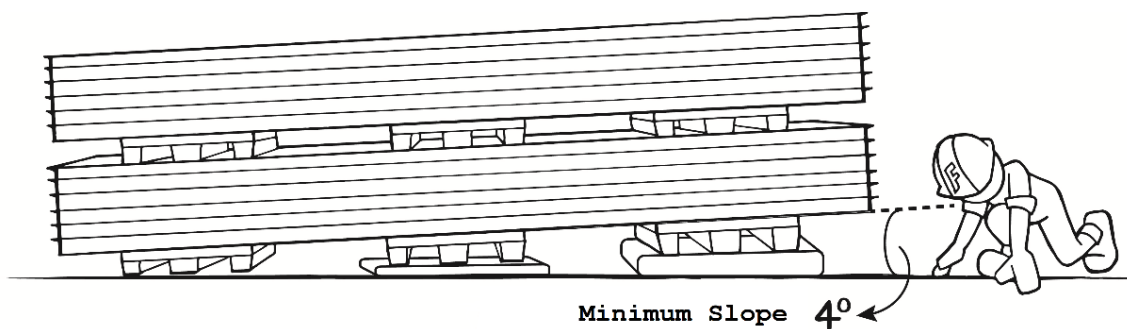
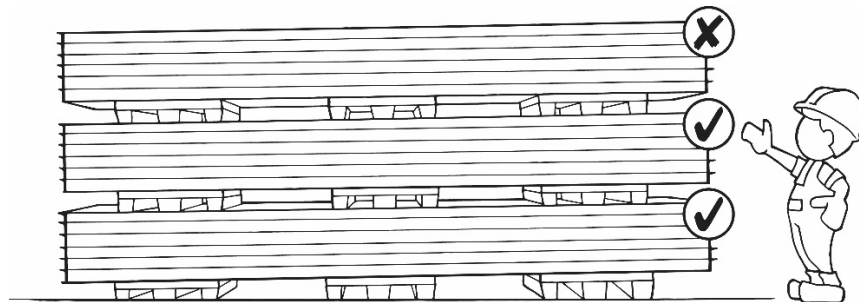

### Unlimited Storage

It is possible to keep panels in storage for a longer period. However, it is still important to remove the protection film within 60 days of manufacturer and/or store the goods indoors if panels are not installed for 90 days. It's highly recommended that you have adequate storage space to receive and store the panel bundles on a paved surface. This space must be level, firm, clean and free from standing water. Bundles should be stored in a dry condition, with one end slightly elevated to facilitate moisture drainage. Avoid outdoor storing for longer than 60 days. Moisture between panels can cause corrosion or staining. Staining of any kind is not considered to be a cause for rejection. If panels are not to be used immediately, then they should be stored under a temporary shelter with the plastic removed from the top and sides of the bundles.

### Lifting Slings

Lifting slings always need to be pulled through below the blocking and bracing. This can be easily prevented by using a wooden support or metal tube that is at least 4 inches longer than the width of the package. Place these below the blocking and bracing and place the lifting slings through them. If necessary, also use temporary side protection such as a protective plate or bumper cushion, on top of the load.

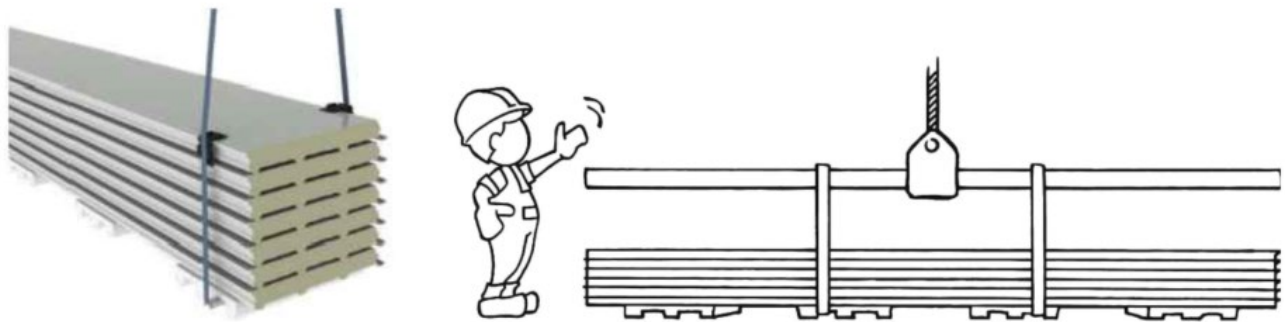

*Do not move any loads above people.* For obvious reasons, loads should never be lifted above people. There is always a chance of something going wrong. Notify people who may walk below a load on time and never lift a load overhead. If possible, it is better to place an obstruction or close off the area.

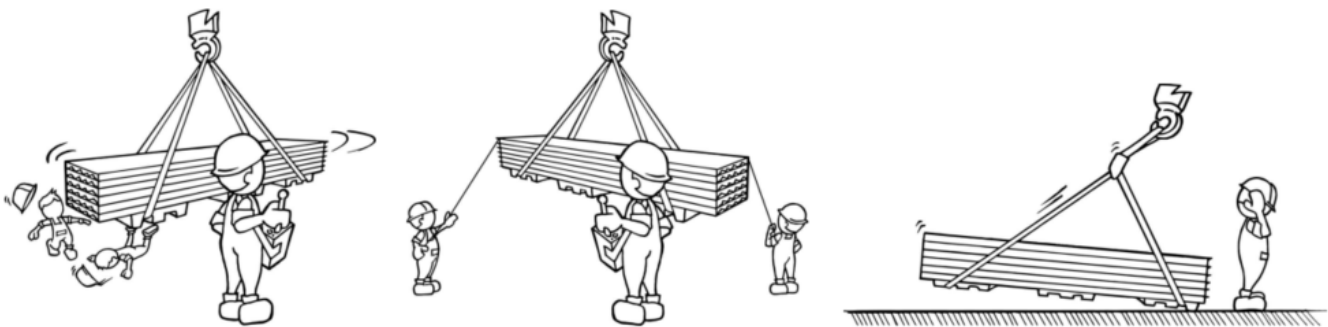

*Pay attention to where you walk.* While operating a crane, most focus is put on the load and the operating unit. However, please do not forget to also pay attention to the load while walking behind the crane. It is better to check for any obstacles beforehand. This will help avoid unnecessary risks. Also avoid walking backwards as much as possible.

### **Vacuum Lifter**

Always lift the panels from the package in a perpendicular position. Due to possible burr formation at the end of the panels damage may occur to the coating of the lower panel when they are not lifted in a perpendicular position. FALK recommends using a suitable and approved vacuum lifter for hoisting the panels. When using a vacuum lifter as your hoisting device the shape and size needs to be adjusted to the panel that requires lifting. This needs to remain in a flat position as much as possible. This is necessary to ensure a balanced division and maximum suction on the element during vertical transportation. Long and thin elements are prone to unwanted dents inflicted during handling.

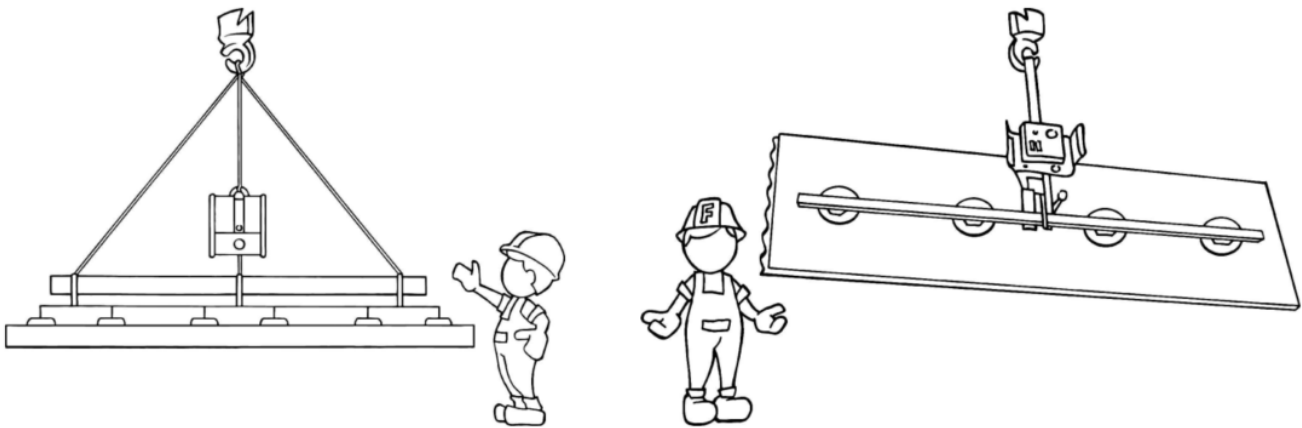

### **Manual Carrying**

Panels should be manually carried on their sides (vertically) and not on the horizontal as this may cause for the sheet to detach (delaminate). Workers should wear appropriate protective gear when handling panels. Failure to do so may cause injury. Be careful not to damage the joint areas as panel engagement may be difficult if joints are damaged.

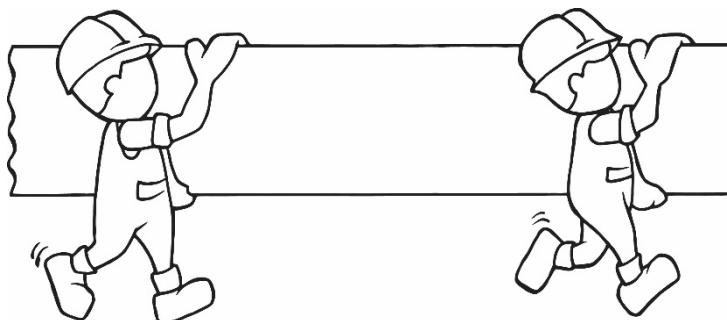

### Job Site Safety & Sealant Applications

While working with FALK IMP's, please look out for sharp edges, burrs, and chips on the elements. Fine dust from the insulation core sometimes causes a skin rash or respiratory irritation. Some injuries may occur when processing and working with panels. Therefore, we advise you to always wear safety goggles or a face mask, gloves, dust mask and protective clothing. To avoid any hearing damage, please wear hearing protection as well.

**Cutting a panel to size** Use the right equipment to cut a panel to size. FALK suggests using a circular saw or panel cutter with a special saw blade suitable for steel sandwich panels, when making modifications to building elements.

Do not use an electric grinder, reciprocating saw, or any tool that may cause serious delamination which affects aesthetics, performance, and panel warranty.

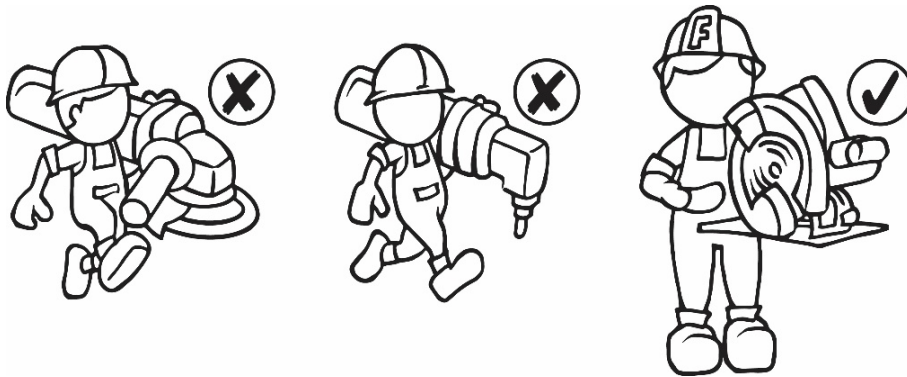

*Caution: Modifying, substituting, cutting, or eliminating critical design component details will impact assemble performance and may nullify one's ability to receive a warranty. System assemblies' performance is tested based on all components working collectively at prescribed diameters and lengths. When modification and substitutions are made to these components, this directly impacts the assembly's performance. FALK cautions this practice and recommends interested parties contact the projects Engineer of Record to perform calculation prior to performing any modification and/or substitution.*

### Jobsite Sealant Applications

Some projects require higher levels of environmental protection from the elements, than the level that can be reached when using the standard joint containing a gasket. When this is the case, the side joint will need to be covered by butyl tape or sealant during the installation process. Apply butyl sealant to interior female joint to ensure proper vapor barrier. Joint should be dry and clean before applying sealant. Fill interior warm female pocket approximately 1/2 to 3/4 full. Add / delete as necessary during panel installation to maintain proper panel seal. In extreme cold weather locations, it may be advisable to caulk both interior and exterior joints. It is also advisable to keep sealants in a warming location until ready for use to ensure proper viscosity and flow rates are achieved.

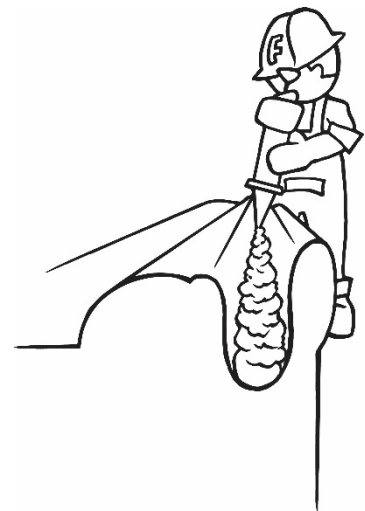

### Roof Panel Installation Procedure

1. As each panel is removed from the bundle, the male and female edges should be visually examined, and any overspill of insulation in the joint area and any excess should be carefully removed.
2. Cut the first RDEK panel along the edge to achieve a flat finished edge as this will be installed along the edge of the roof.
3. The RDEK panel should be laid flush with the face of the wall panel, parapet or roof nailer as shown on the FALK shop drawings or standard details. It is important that the first tier of panels is laid true to line, properly lined with a string to ensure a true and square fit.
4. The starter panel should be fastened along the rake supporting member in the required spacing as shown in the FALK shop drawings. Typically, 12" OC is required.
5. RDEK pressure plates and two fasteners will be affixed to each supporting member at designated spans.
6. Subsequently the tongue and groove RDEK panels will be placed next to the initial and subsequent panels while being slid laterally to mate the panels. As each panel is positioned in place, ensure a watertight joint is achieved and the corresponding pressure plate and fasteners are affixed to each supporting member at the given span. (Repeat as needed to complete installation.)
7. It is recommended that if the RDEK panels will be exposed to environmental conditions for 7 days or longer and not waterproofed with a thermoplastic commercial roofing membrane, that all joints and butt joints receive a non-skinning butyl caulk in the joint and 4" FSK tape be place over each side joint and butt joint, to prevent moisture from entering the building.
8. When the RDEK assembly is complete and/or section is completed, position the coil batten strip over the supporting members and affix per wind uplift requirements. (Visit RDEK40 Installation details for standard and enhanced layouts.)
9. Adequate caulking and sealing of the panels and trims is the sole responsibility of the installing contractor.
10. Once the coil batten is fully installed, the thermoplastic commercial roofing membrane may be installed per manufacturer guidelines.
11. Follow all roofing detailing requirements and instructions per manufacturer warranty guidelines.

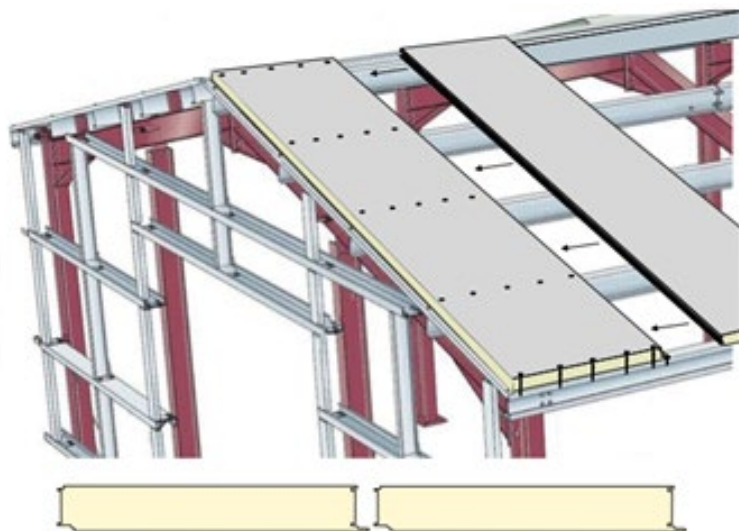

## RDEK40 PANEL INSTALLATION DETAILS

### Standard - 2", 6" O.C. Fastening Diaphragm

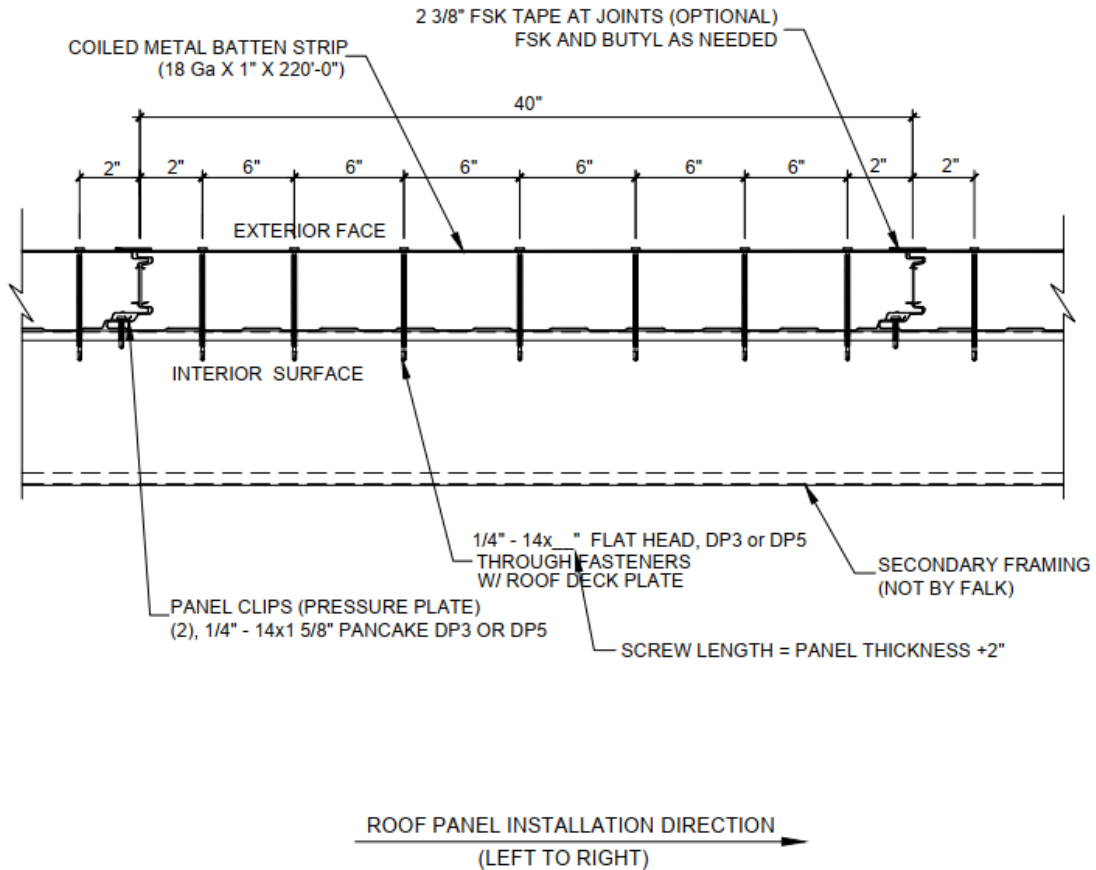

**NOTE:** THE FASTENING SCHEDULE MAY VARY DEPENDING ON SPECIFIC APPLICATION.

### Standard - 2", 12" O.C. Fastening Diaphragm

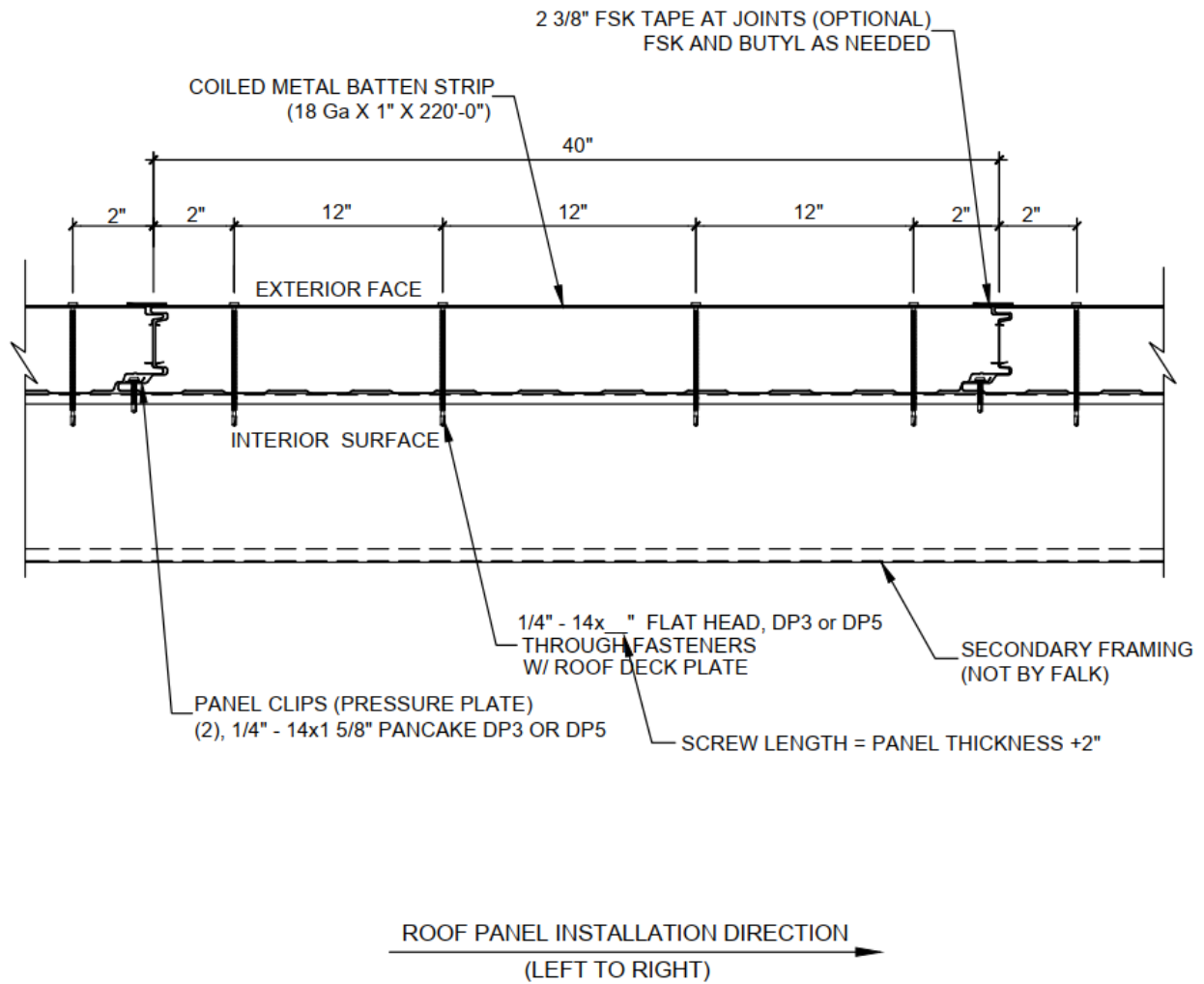

NOTE: THE FASTENING SCHEDULE MAY VARY DEPENDING ON SPECIFIC APPLICATION.

**Enhanced- 20" O.C. Fastening Diaphragm (Enhanced)**

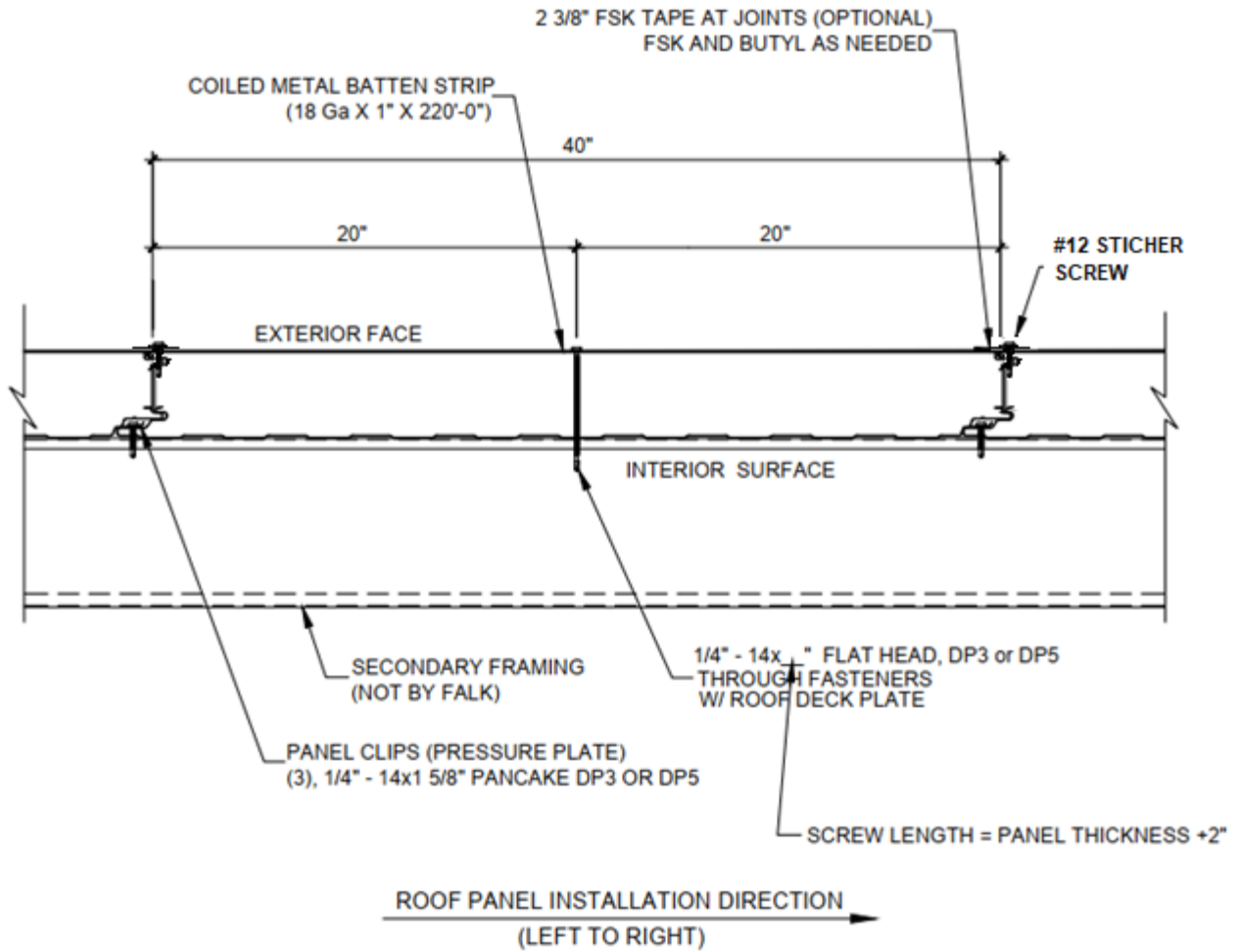

NOTE: THE FASTENING SCHEDULE MAY VARY DEPENDING ON SPECIFIC APPLICATION.



**Enhanced - 2", 18" O.C. Fastening Diaphragm (Enhanced)**

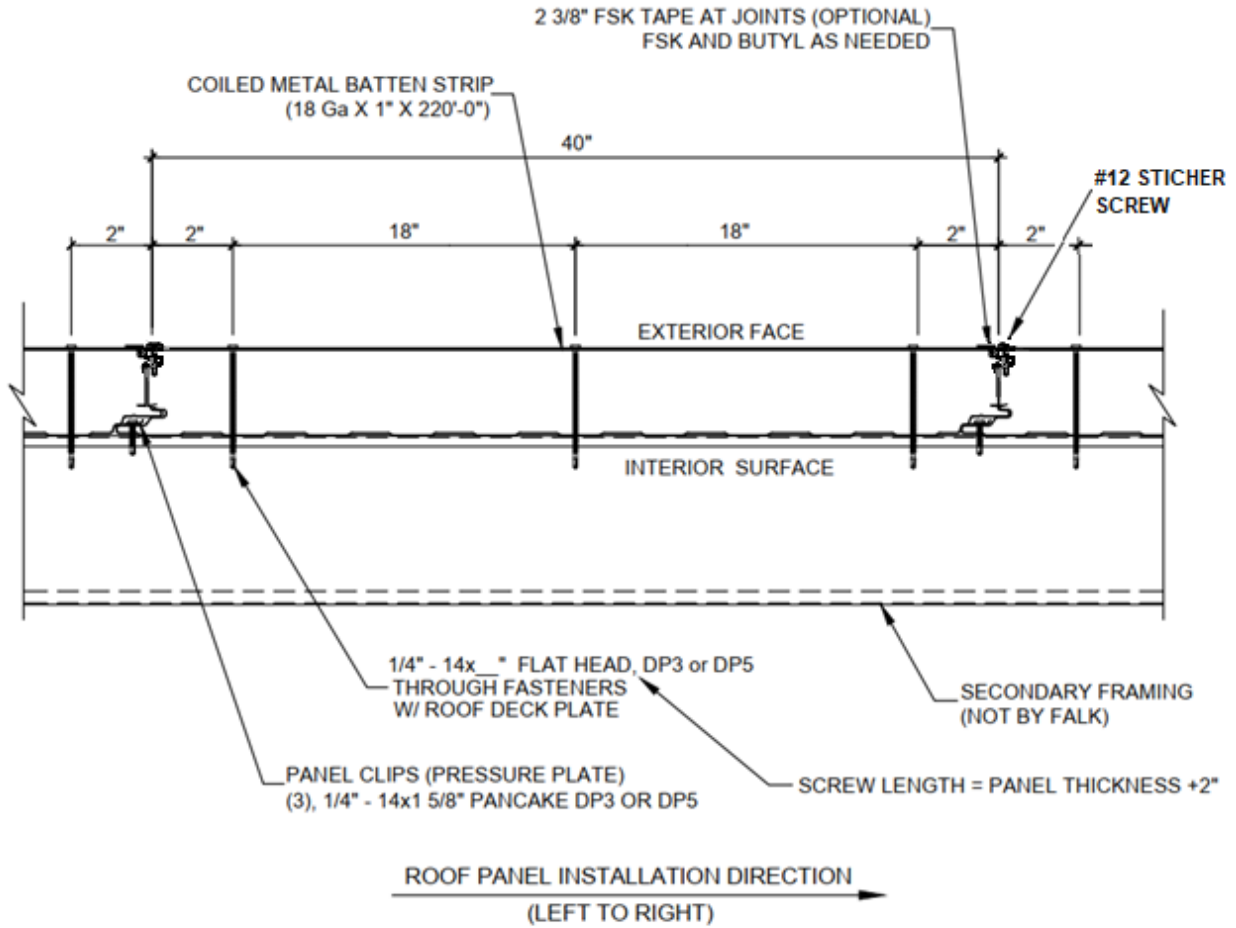

NOTE: THE FASTENING SCHEDULE MAY VARY DEPENDING ON SPECIFIC APPLICATION.

### Standard RDEK Joint Detail

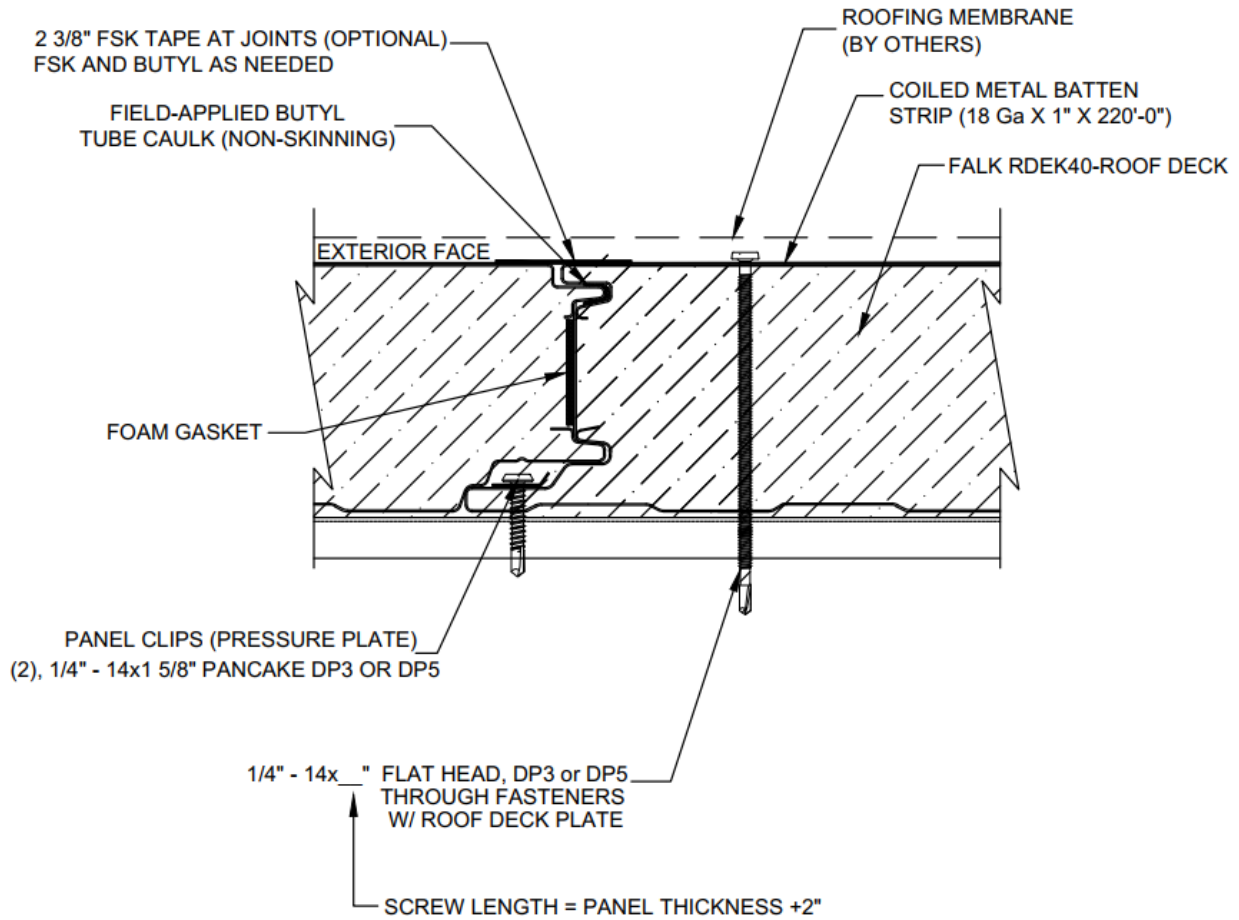

NOTE: THE FASTENING SCHEDULE MAY VARY DEPENDING ON SPECIFIC APPLICATION.

### Enhanced RDEK Joint Detail

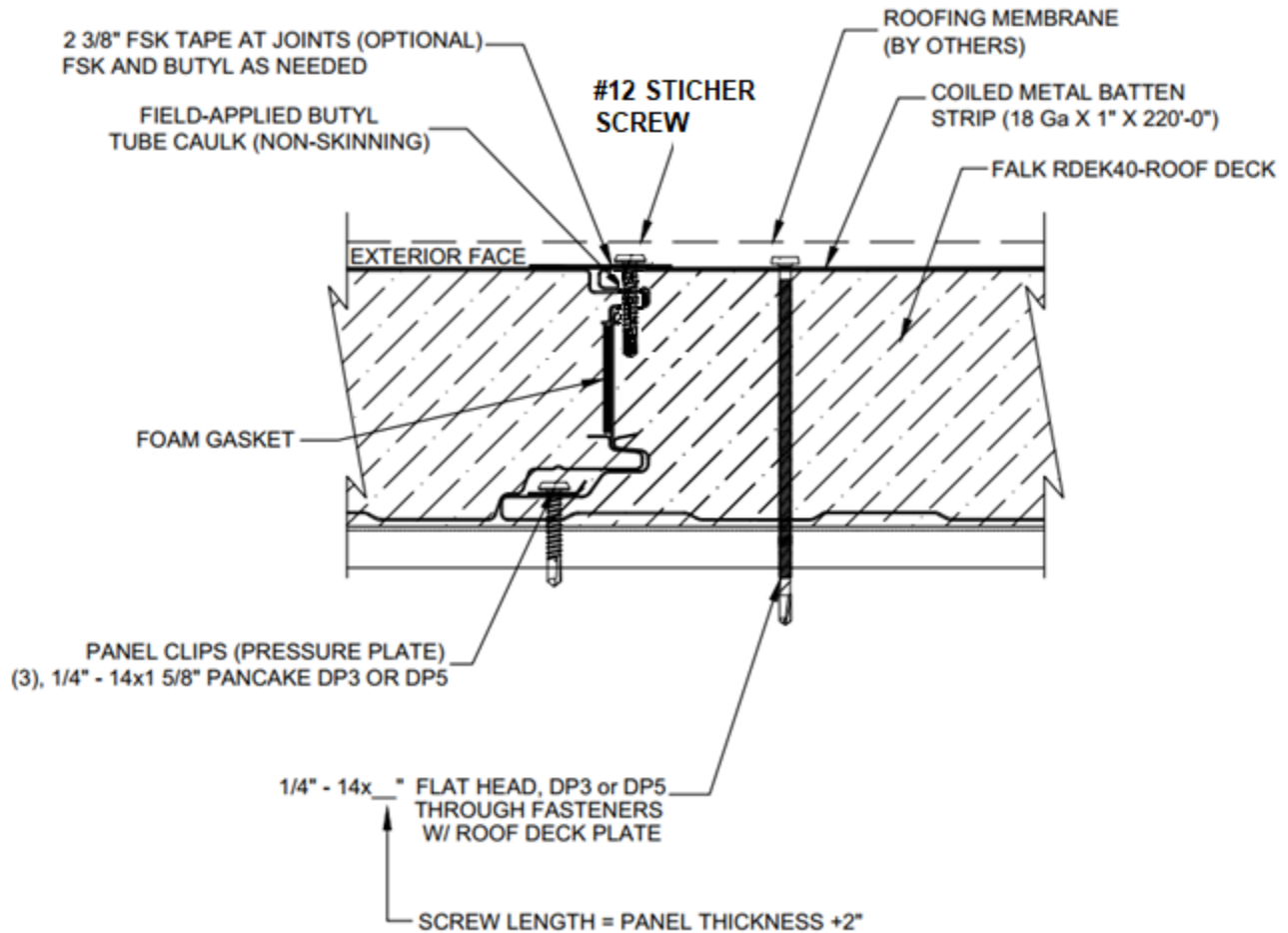

NOTE: THE FASTENING SCHEDULE MAY VARY DEPENDING ON SPECIFIC APPLICATION.

## Intermediate Roof Fastening

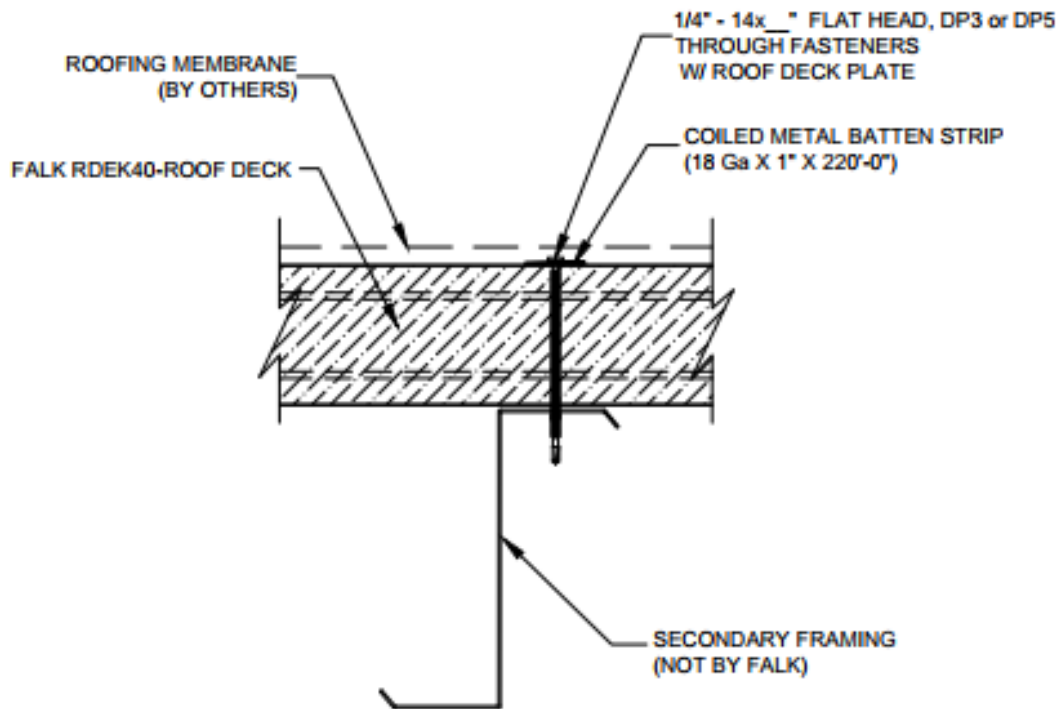

NOTE: THE FASTENING SCHEDULE MAY VARY DEPENDING ON SPECIFIC APPLICATION.

## Butt Joint Detail

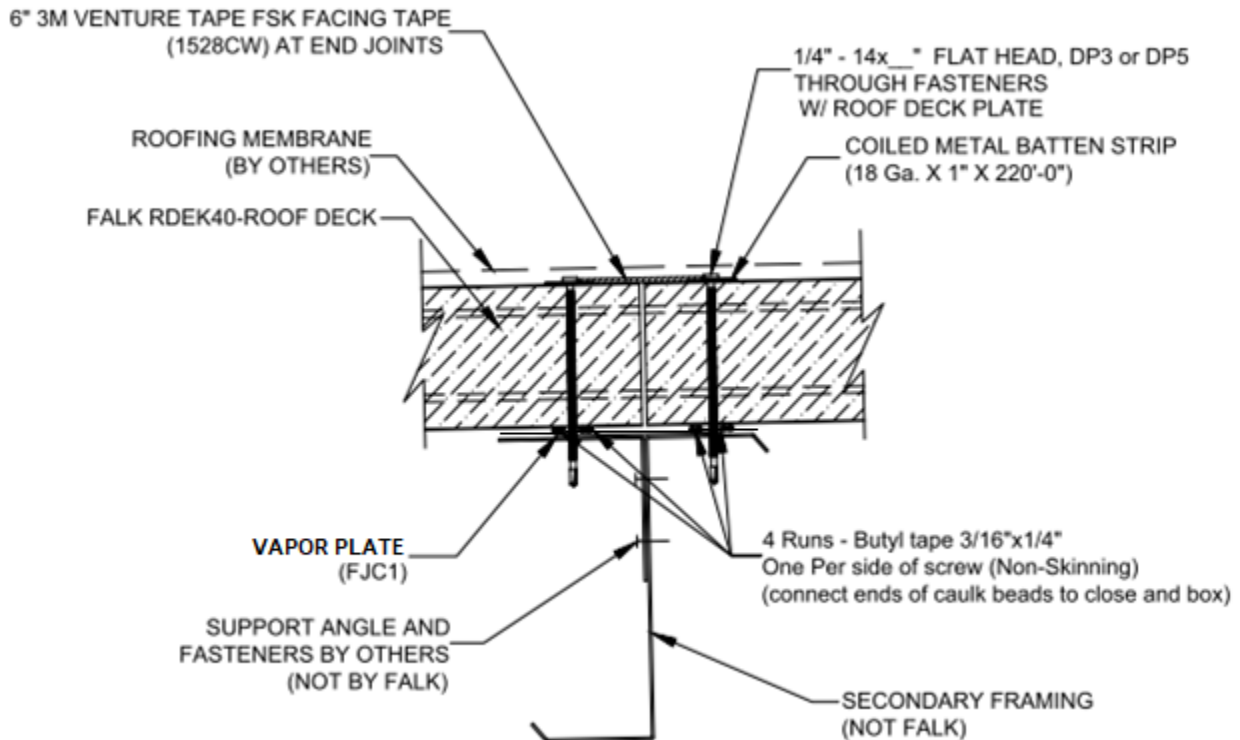

NOTE: ENGINEER OF RECORD TO DETERMINE THE REQUIRED ATTACHMENT METHOD OF SUPPORT ANGLE TO PURLIN AND ENSURE CONTINUITY OF SHEAR LOAD TRANSFER AT THIS LOCATION.

### Butt Joint Detail on Joist

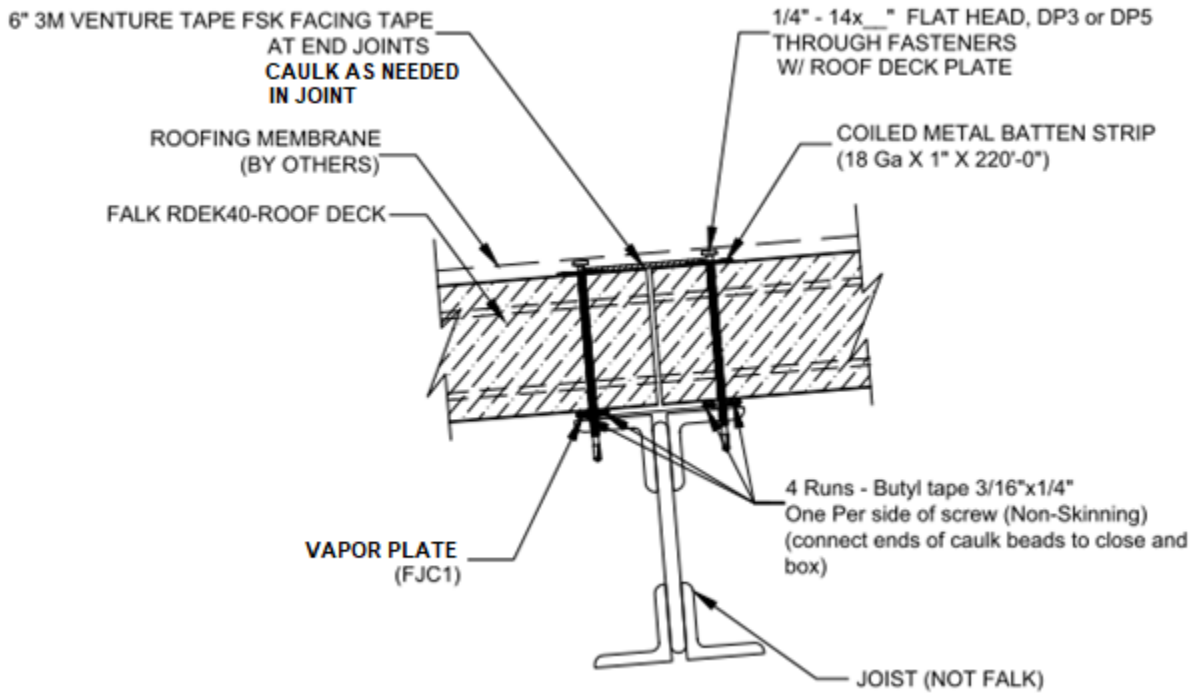

## Ridge Detail

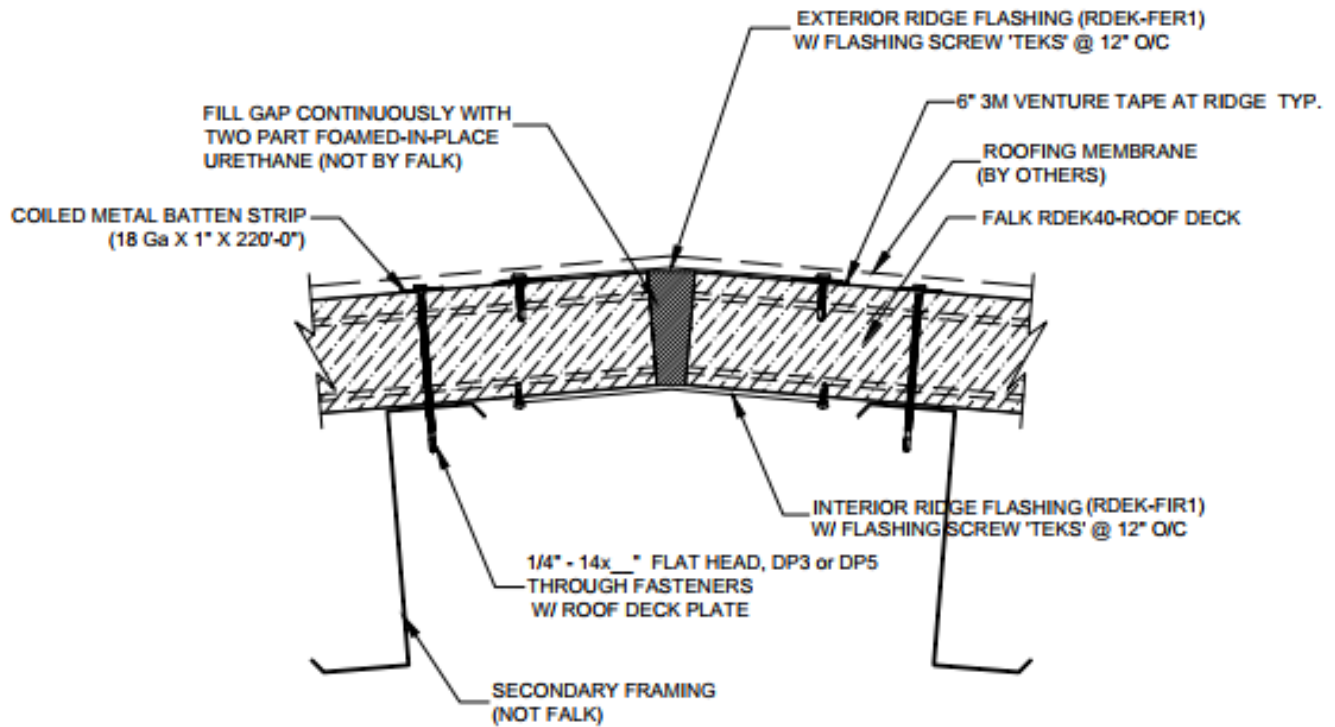

## Expansion Joint Details

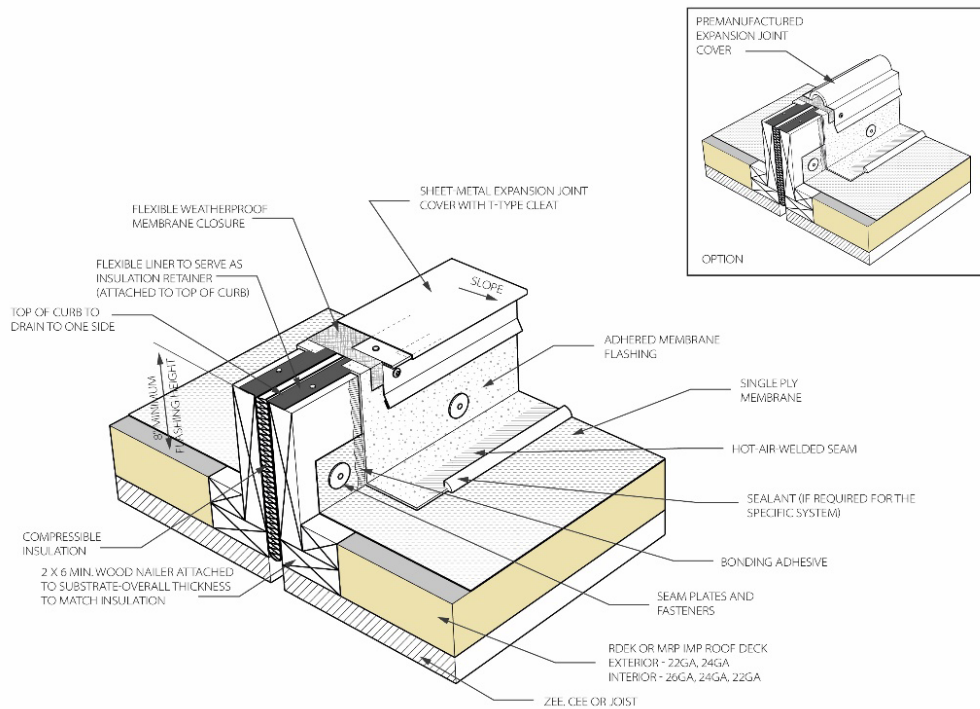
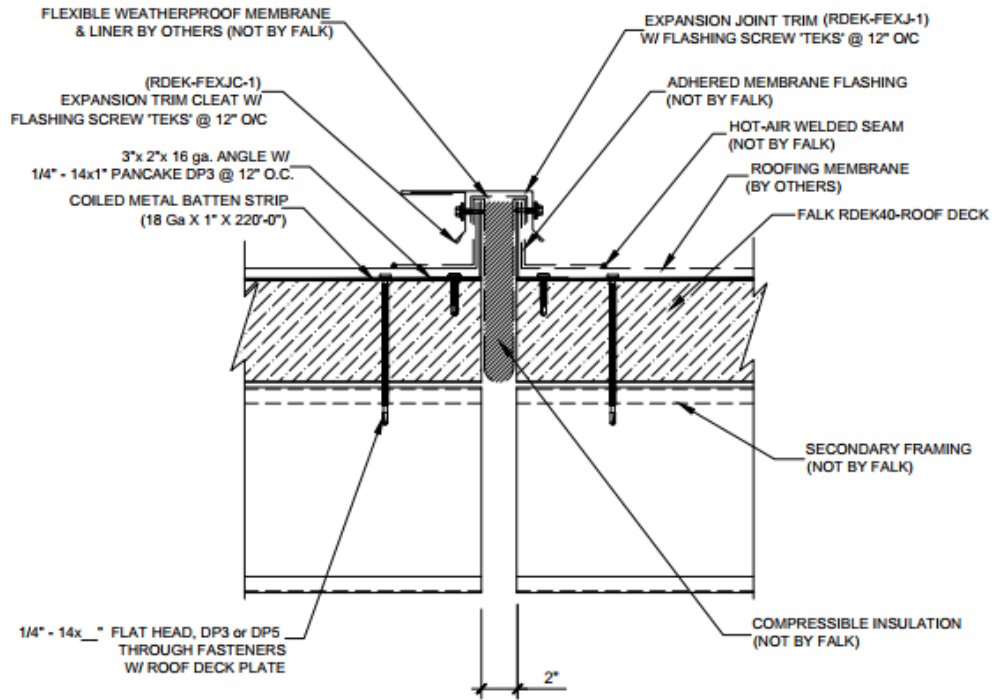



### Low Eave Detail (Gutter by Others)

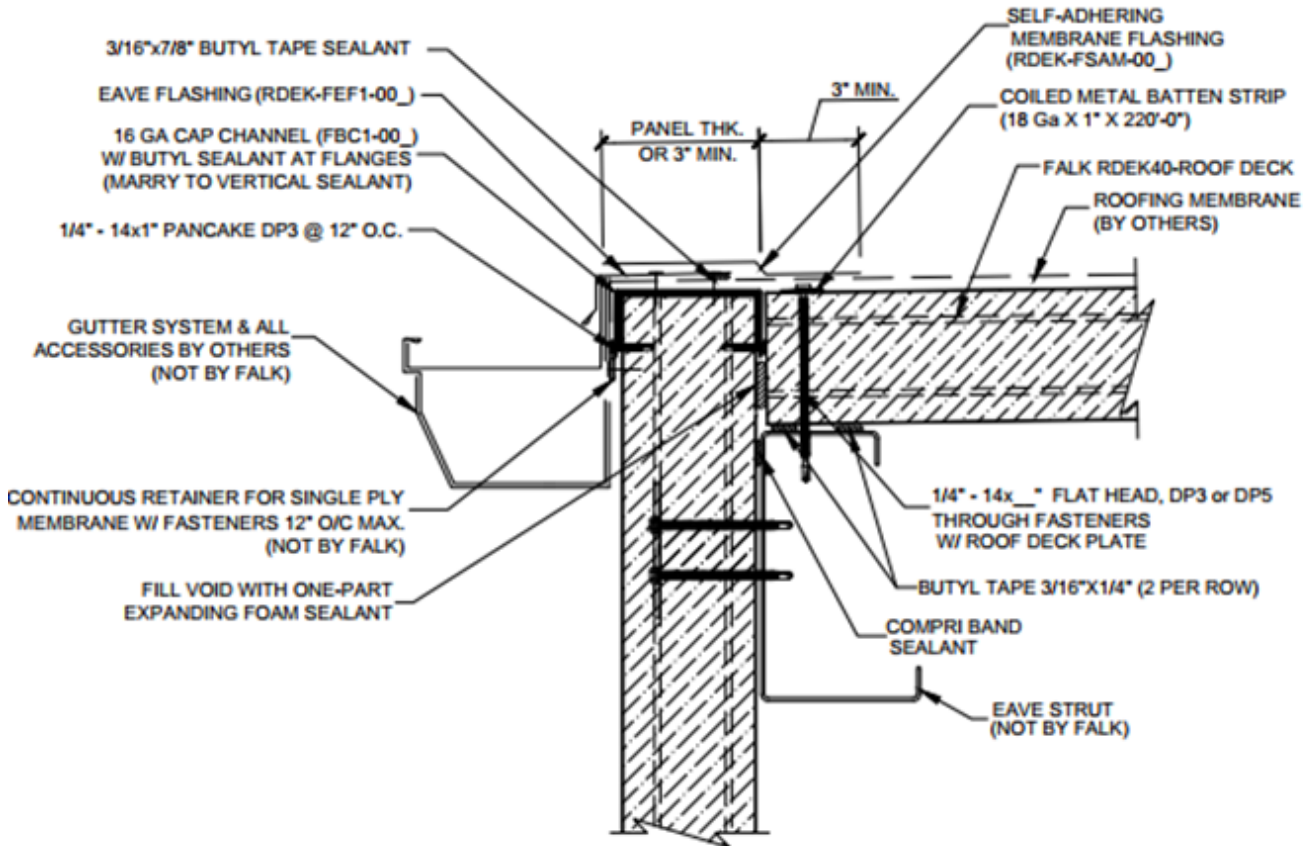

NOTE: BUTYL SEALANT AT WALL JOINERY NOT SHOWN FOR CLARITY. ENSURE ALL SEALANTS MARRY TO CREATE A THERMAL ENVELOPE.

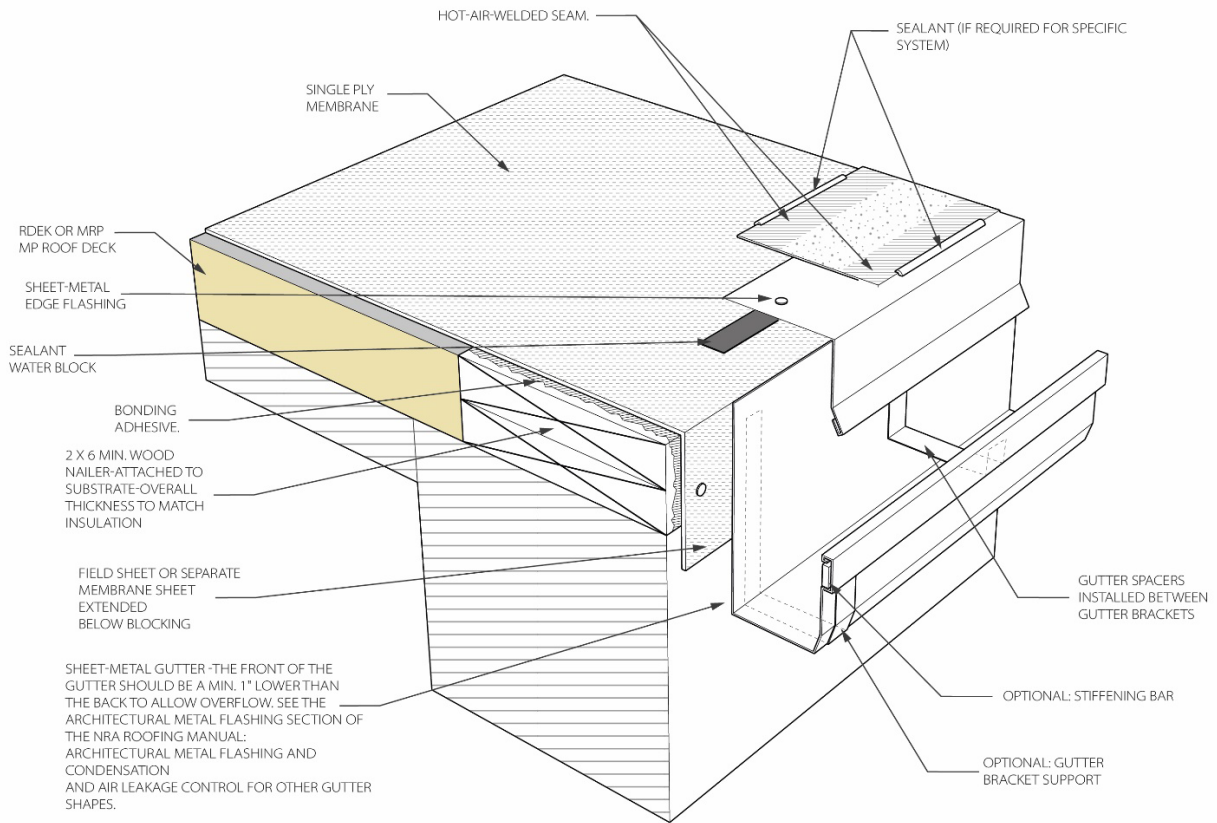

## Rake Detail W/ Rake Flashing

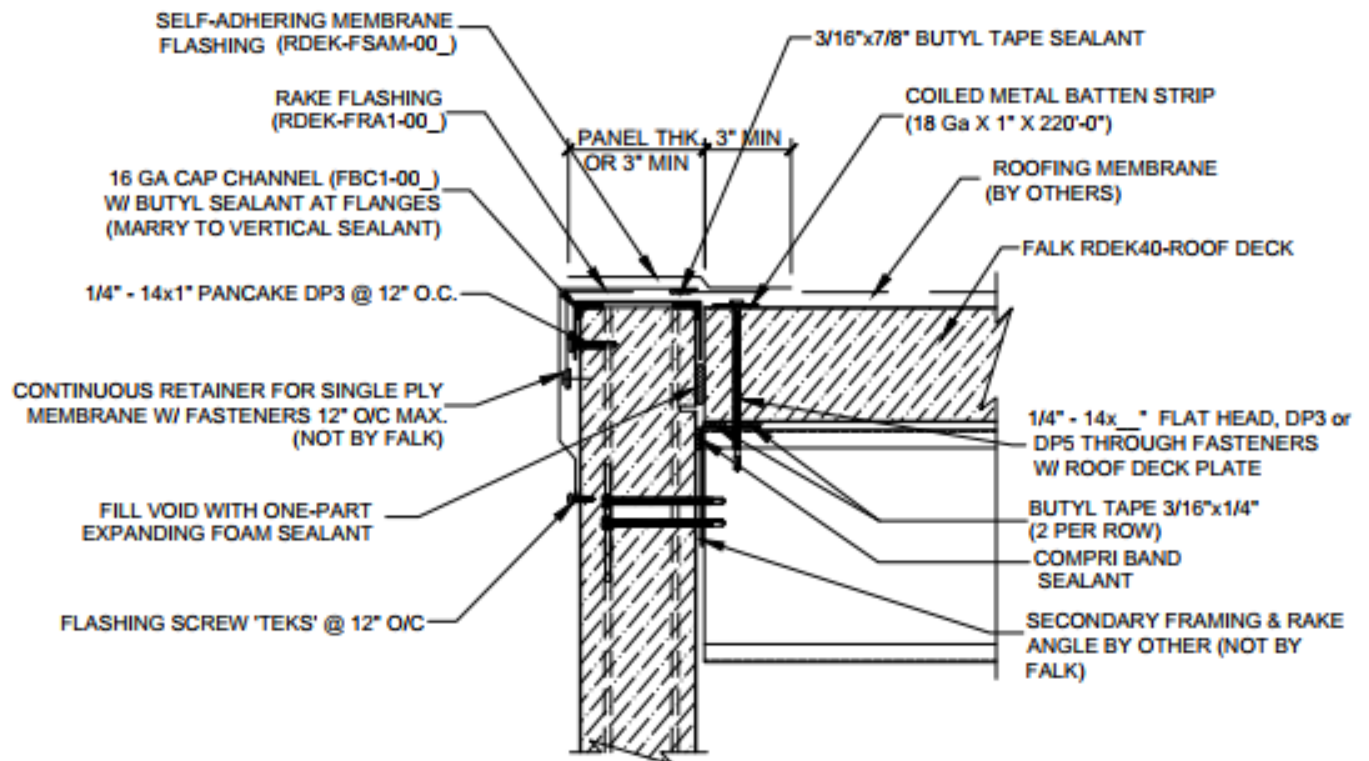

NOTE: BUTYL SEALANT AT WALL JOINERY NOT SHOWN FOR CLARITY. ENSURE ALL SEALANTS MARRY TO CREATE A THERMAL ENVELOPE.

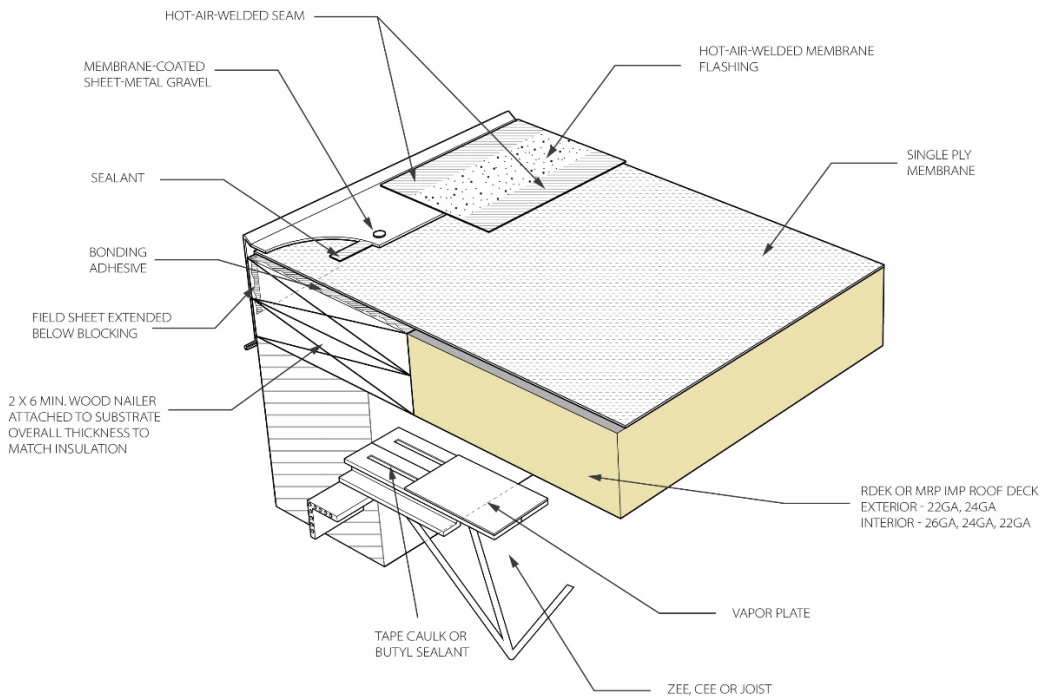
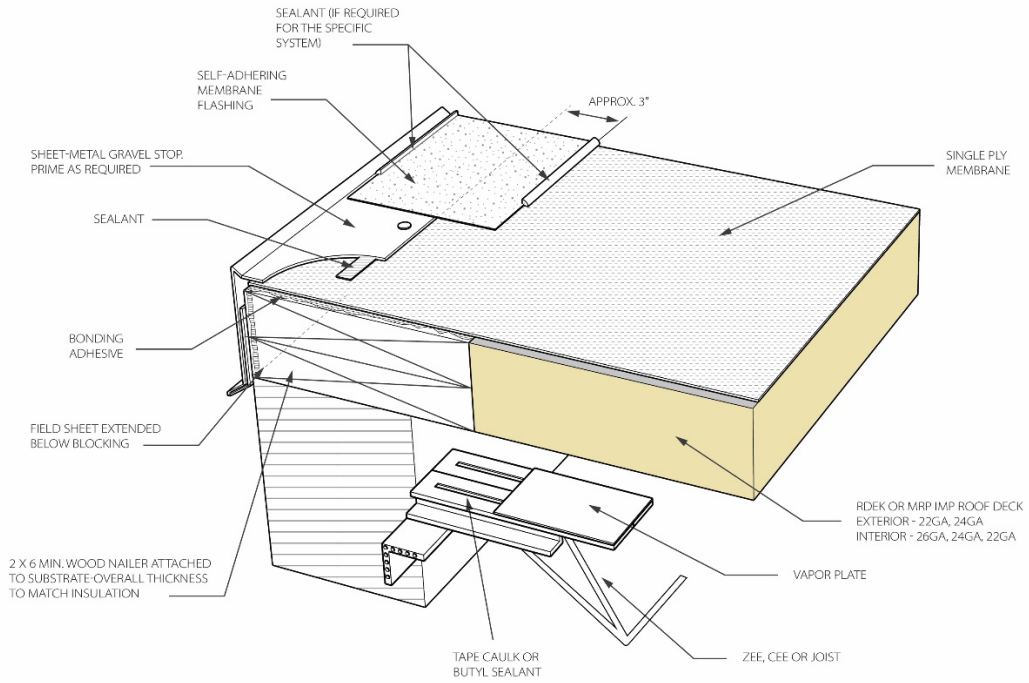

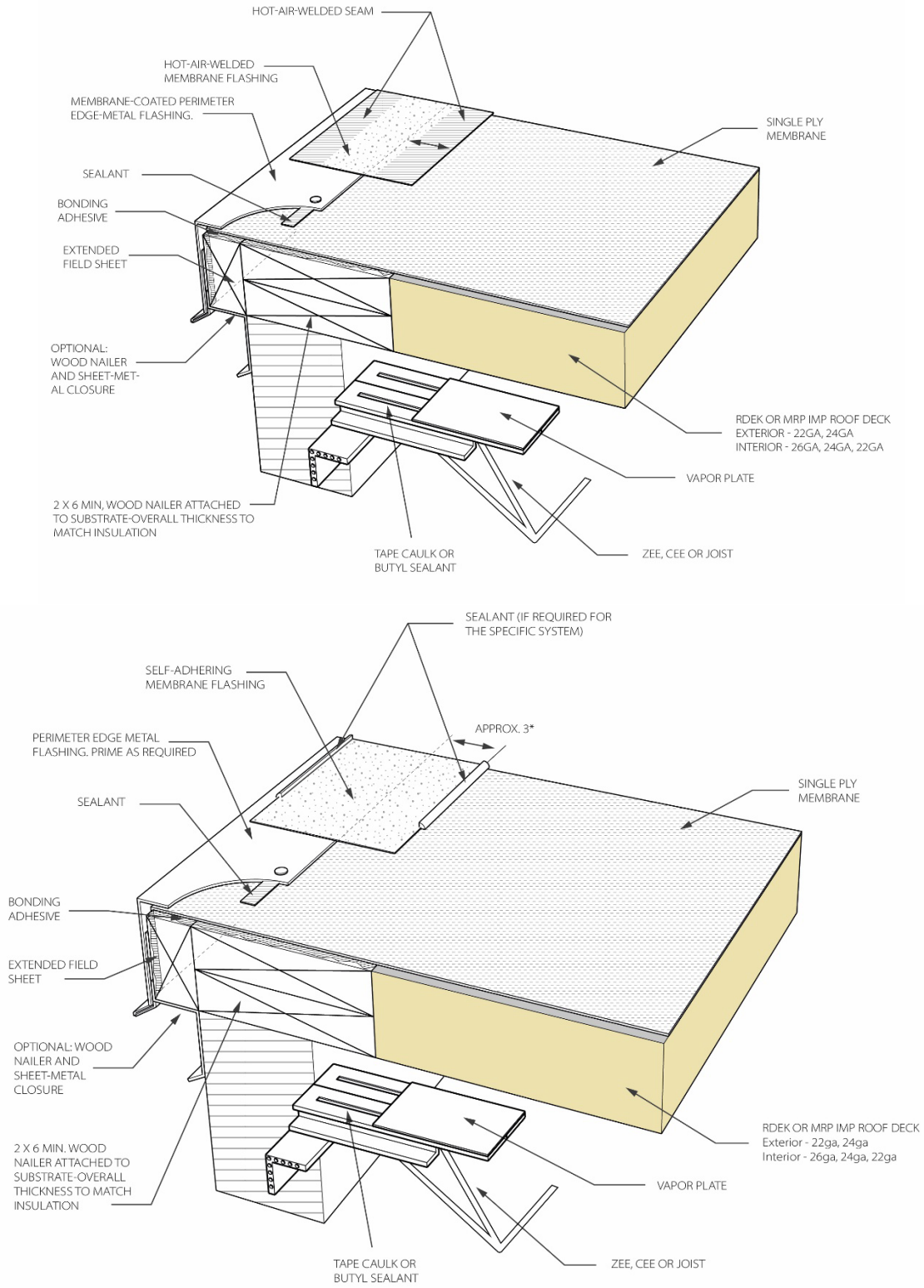

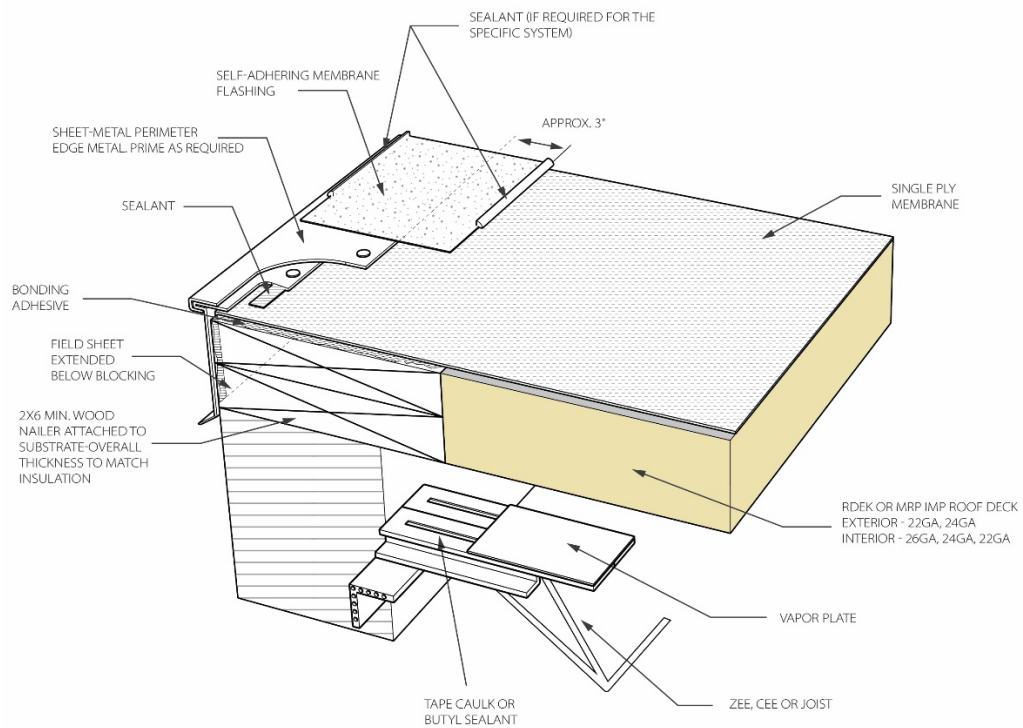
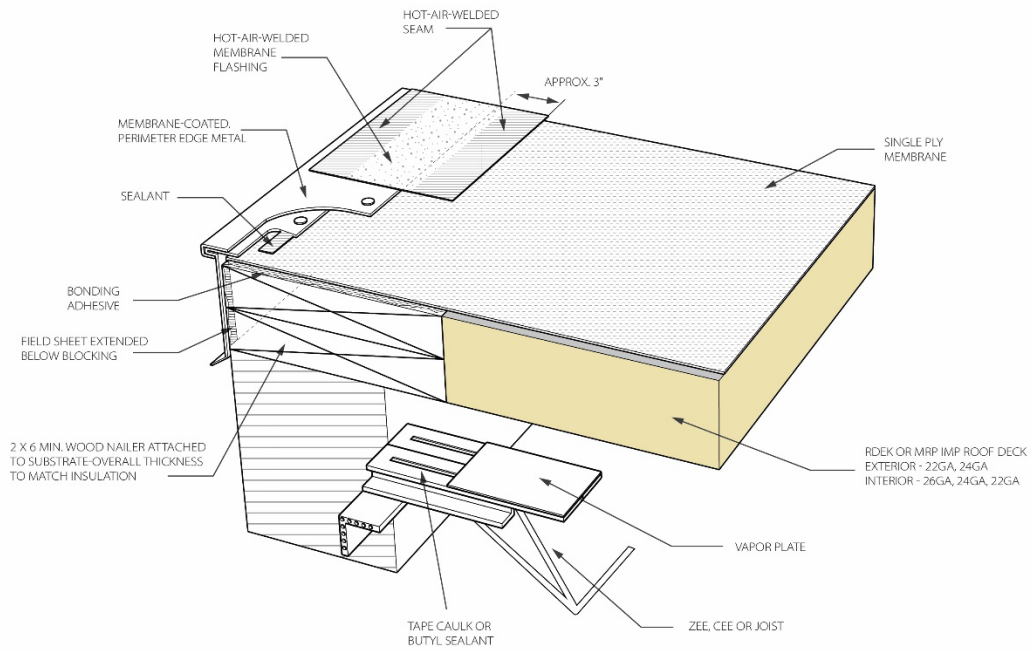

## High Eave Detail W / High Eave Transition Trim

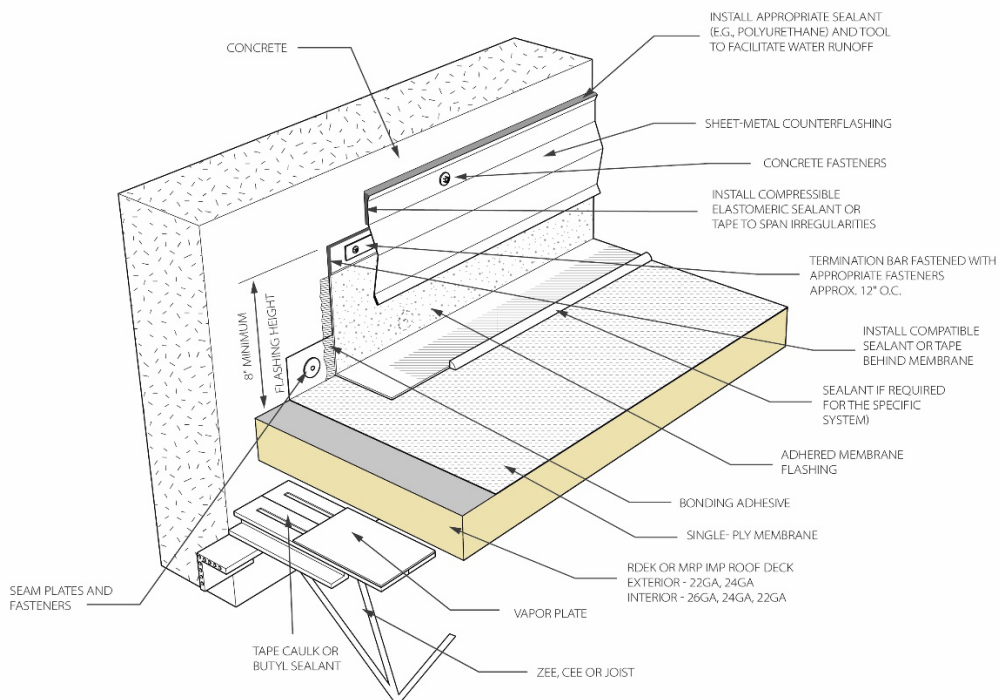
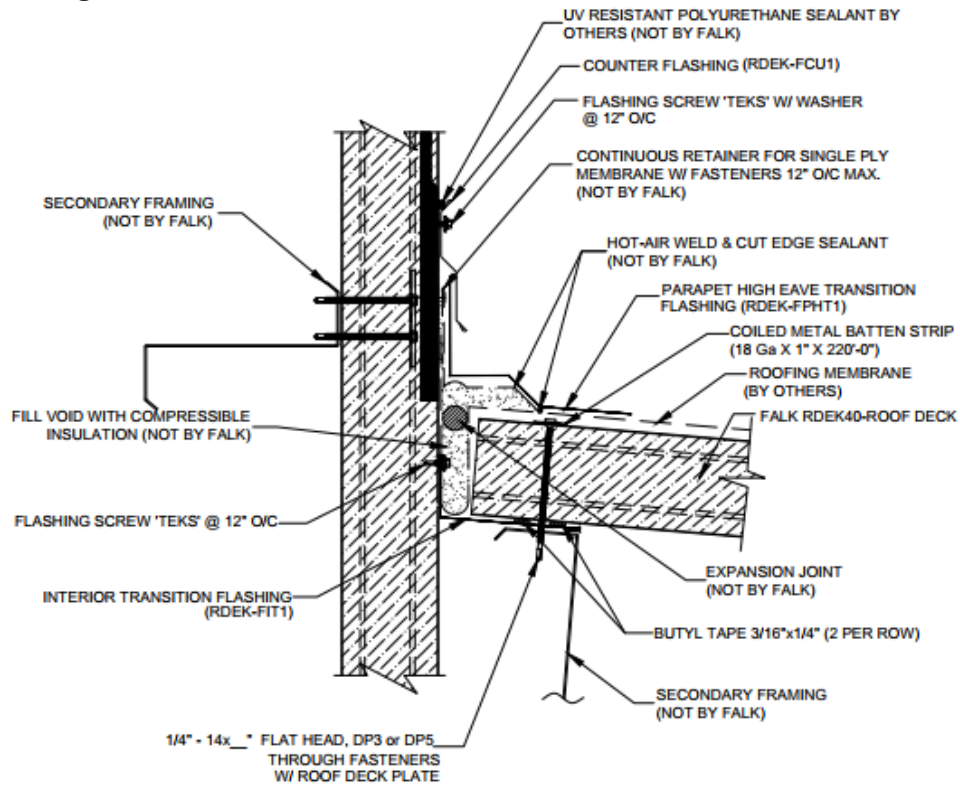

## Rake Detail W / Rake Transition Trim

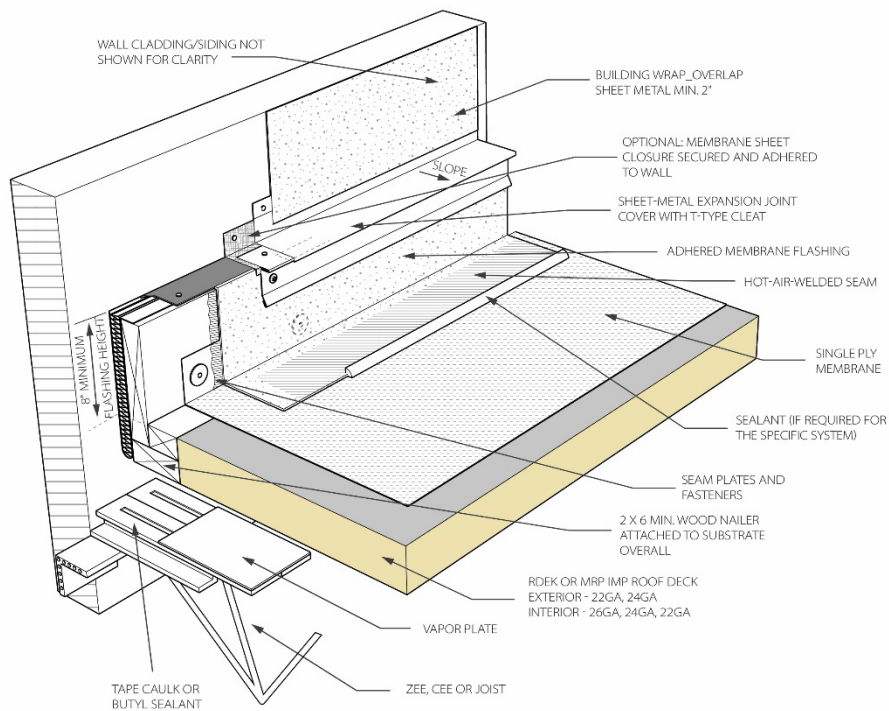
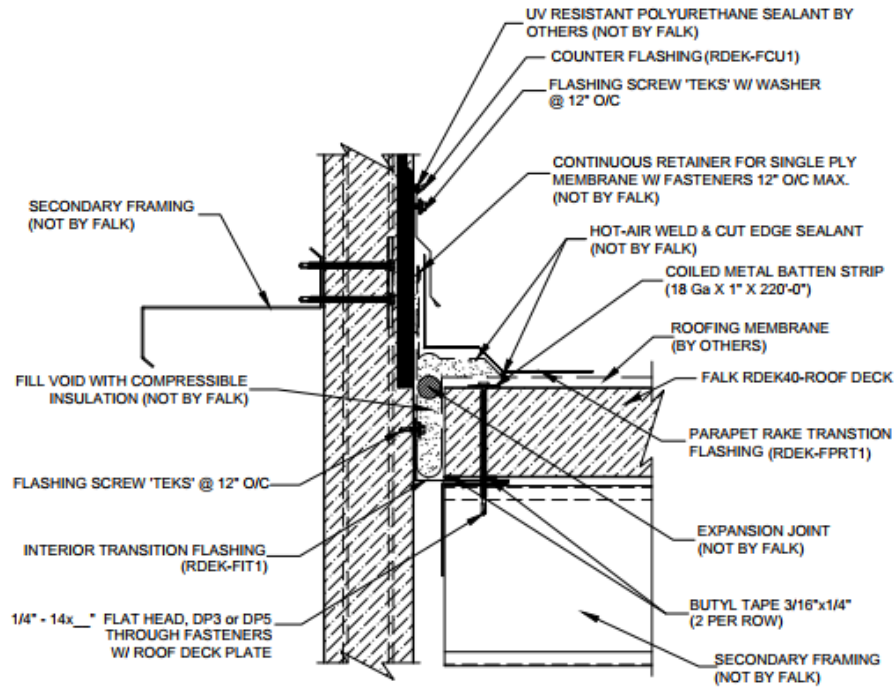



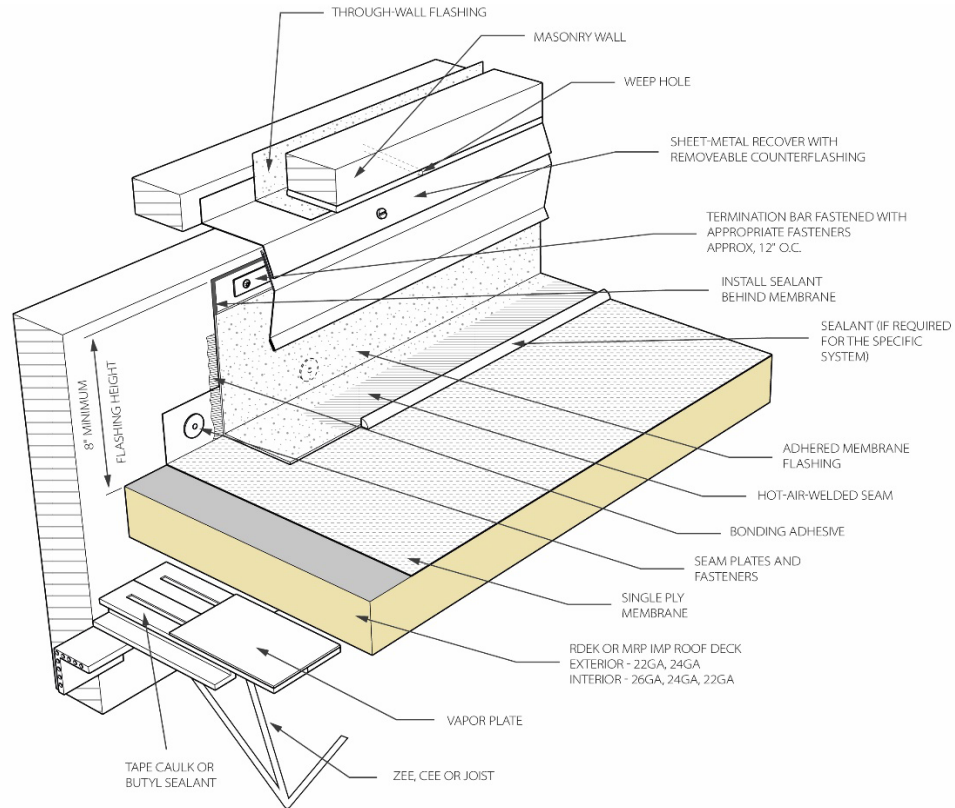

## Parapet Cap W/ Metal Coping (At Low Side Eave)

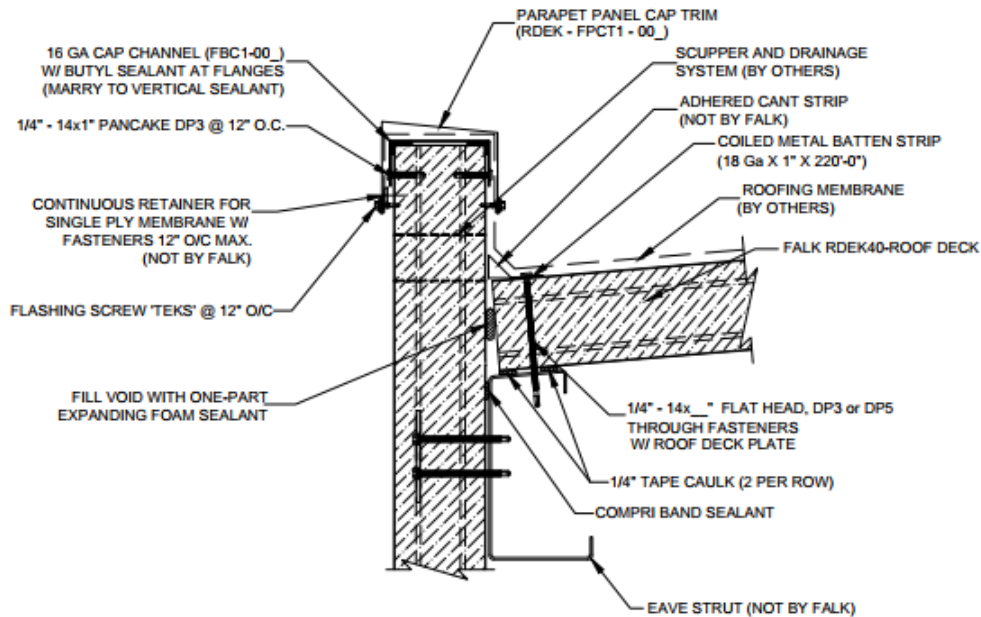

NOTE: BUTYL SEALANT AT WALL JOINERY NOT SHOWN FOR CLARITY. ENSURE ALL SEALANTS MARRY TO CREATE A THERMAL ENVELOPE.

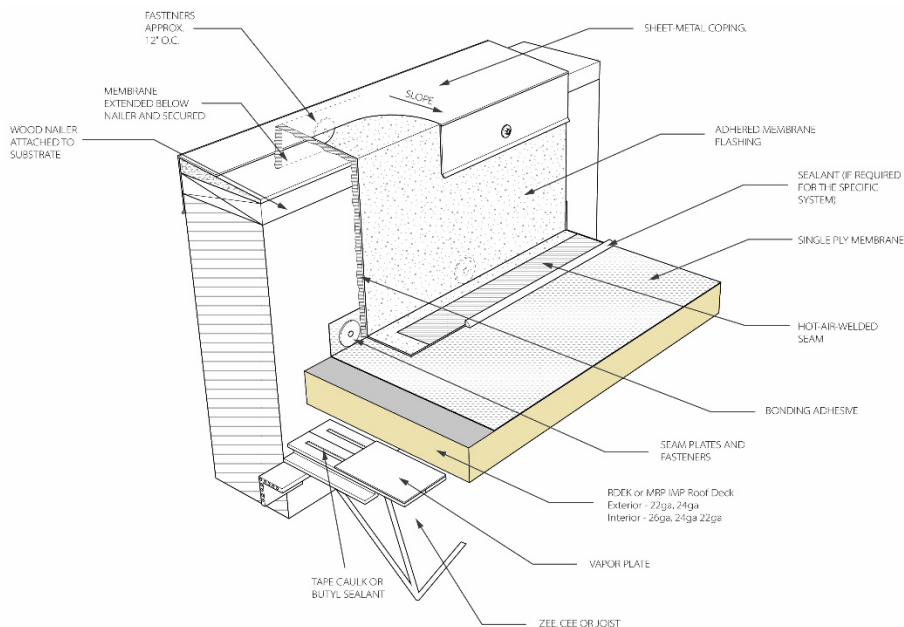

## Parapet Cap W/ Metal Coping (At Rake)

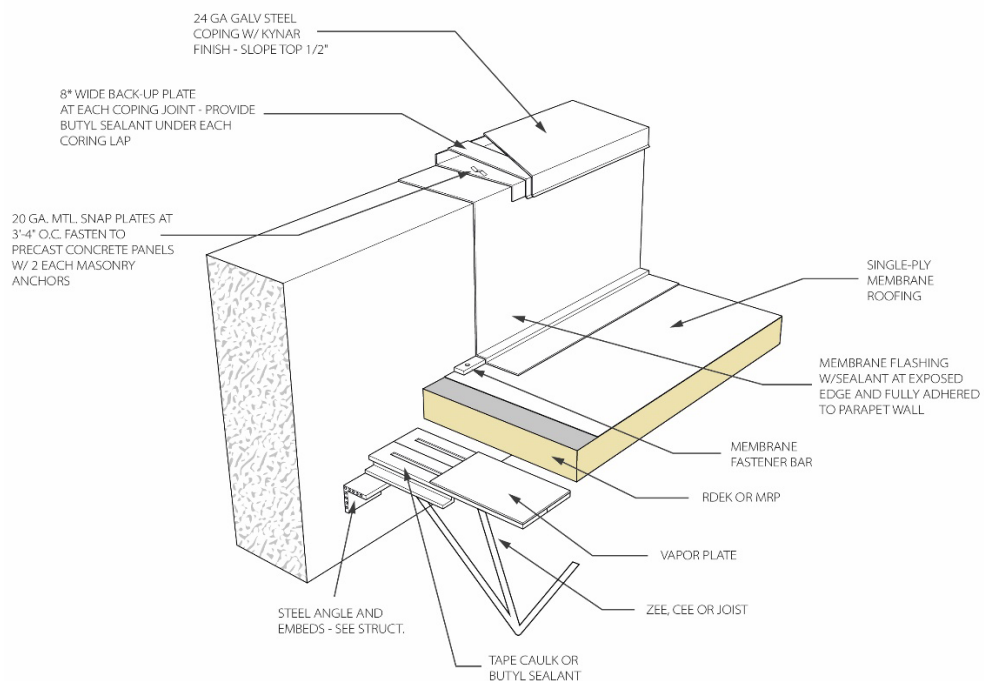
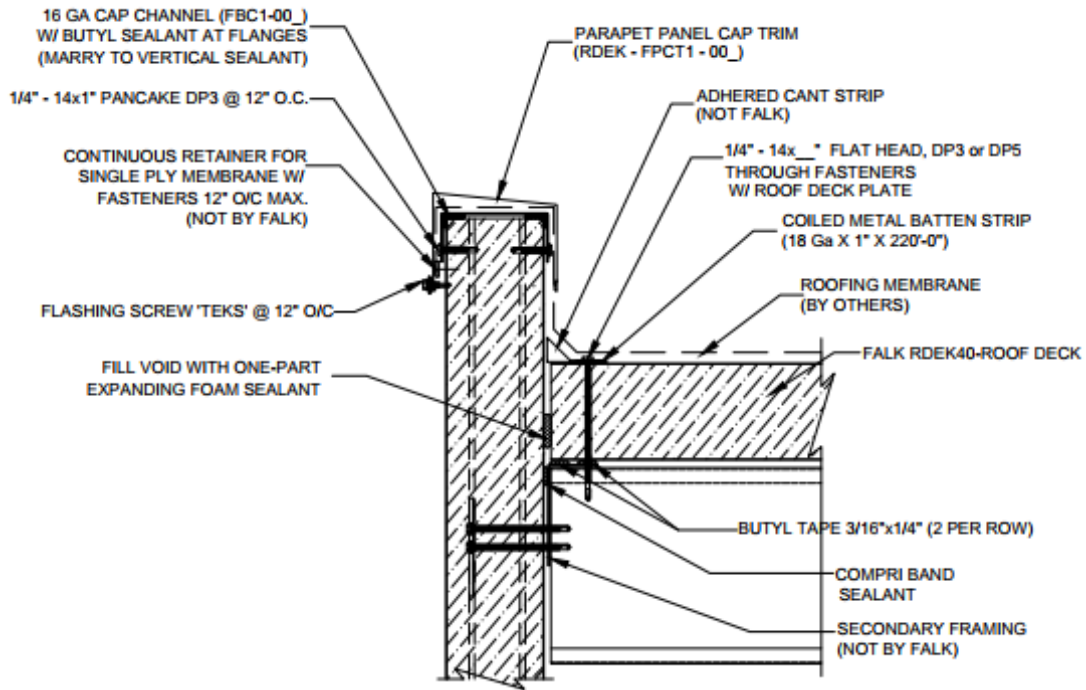

### Rake Detail W / Counter Flashing

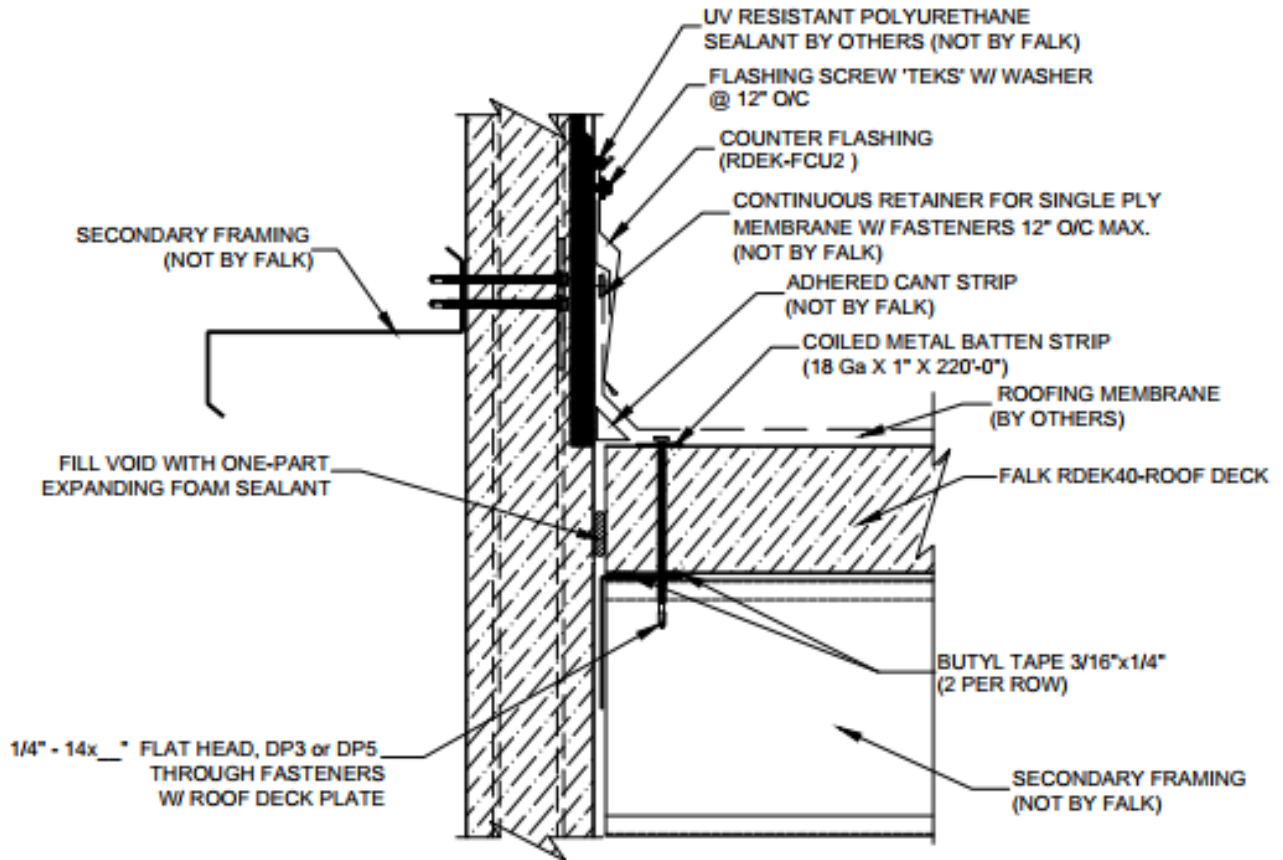

## High Eave Detail W / Counter Flashing

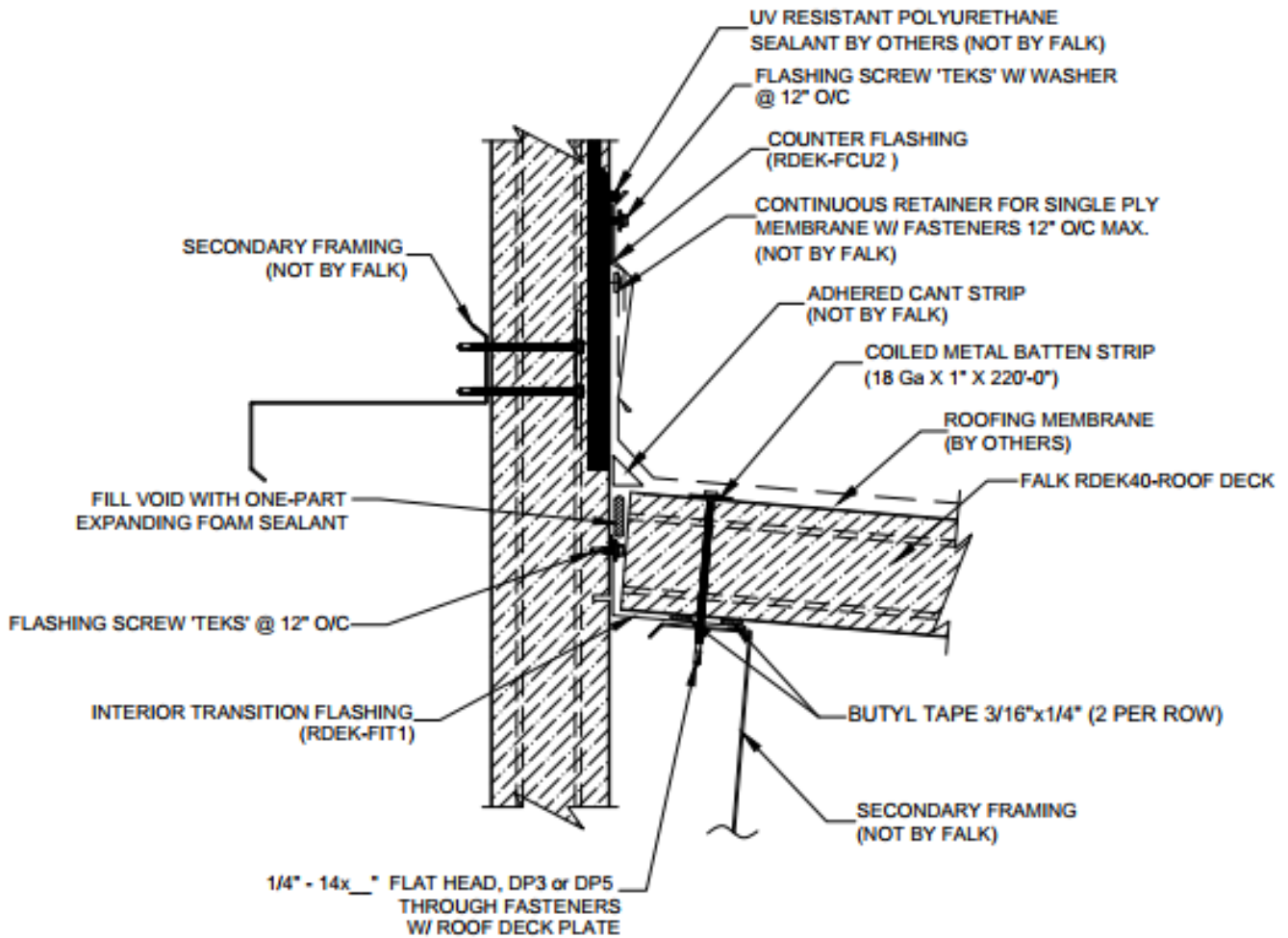

## Penetration At Roof Deck – Molded Pipe Boot

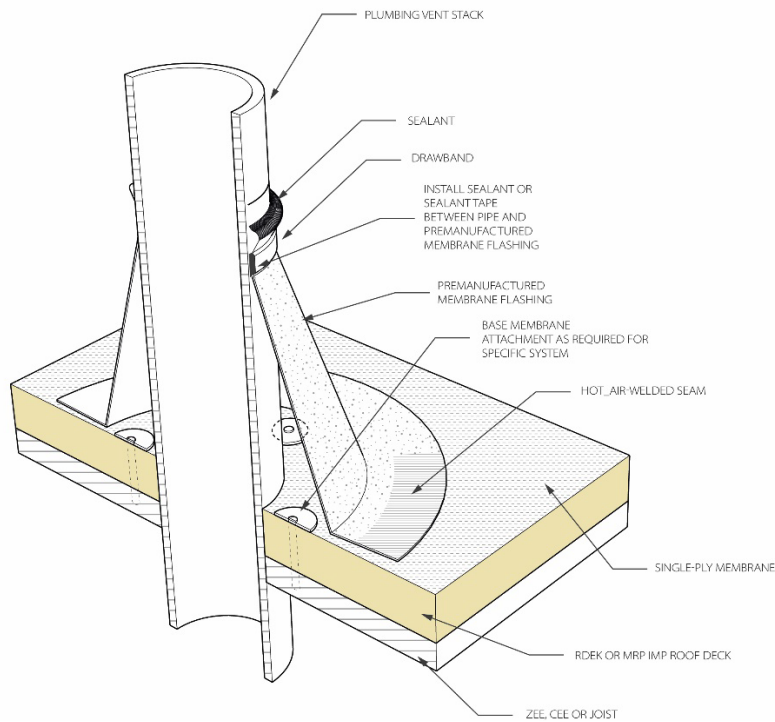
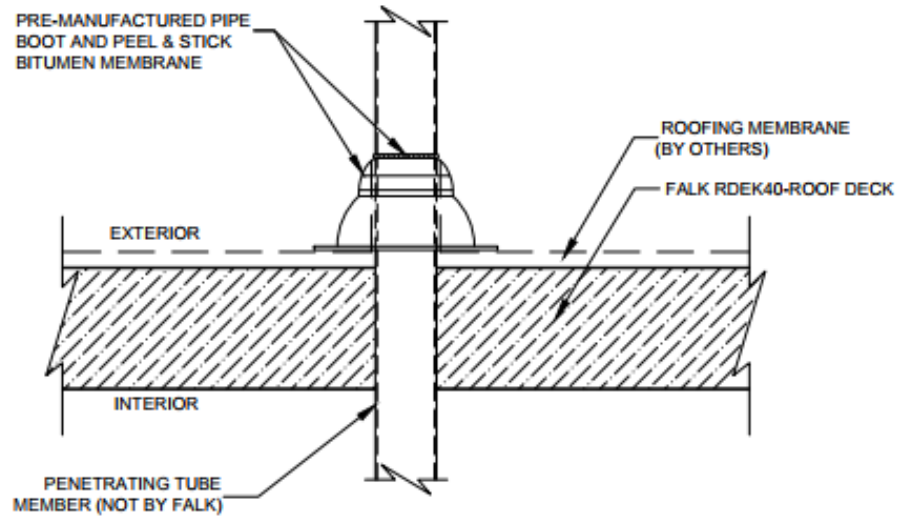

## Penetration At Roof Deck – Molded Pipe Boot Single and Multi Pipe

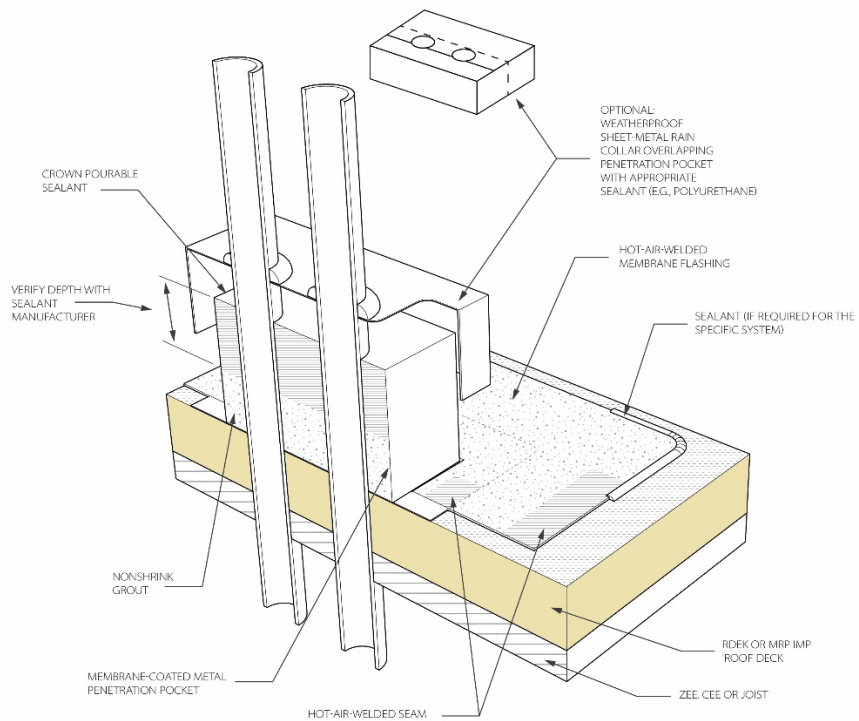
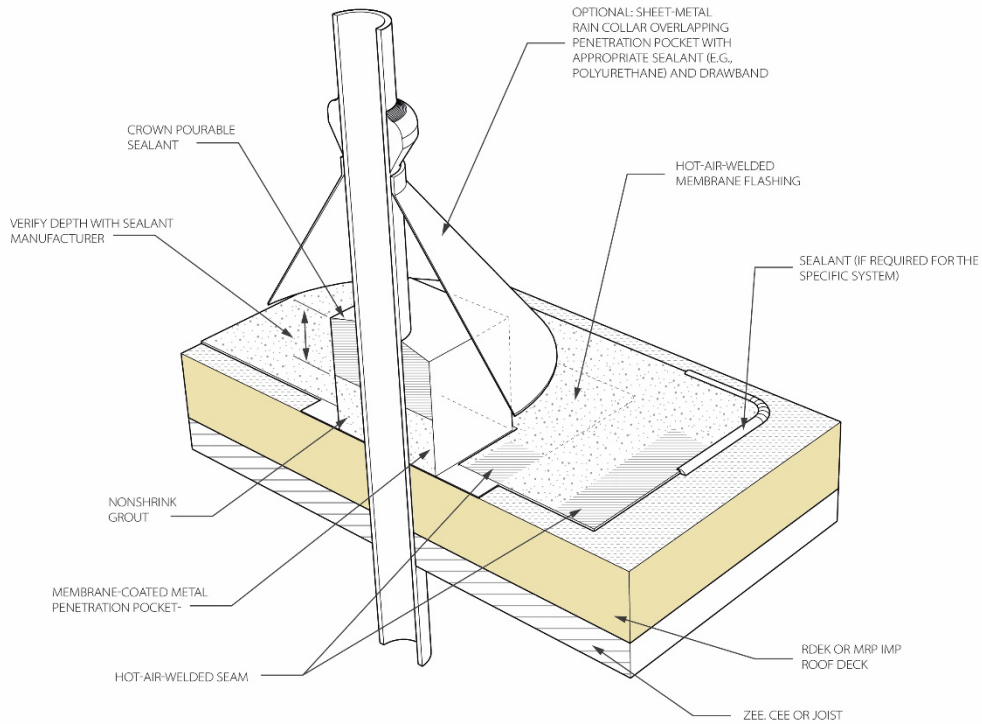

### Penetration At Roof Deck- Field Fabricated

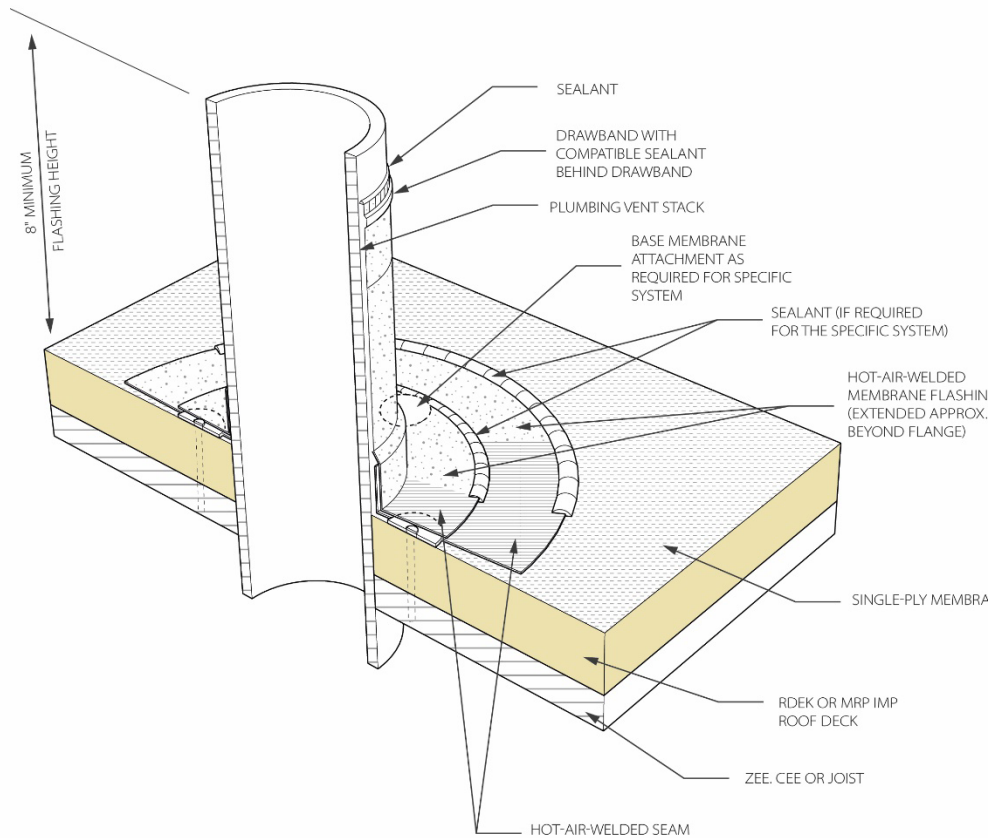

NOTE: 1. PANEL FASTENERS AND JOINERY SEALANTS NOT SHOWN FOR CLARITY.

2. FILL VOID(S) WITH ONE-PART EXPANDING FOAM SEALANT.



## Raised Perimeter Edge With Metal Flashing [Fascia Cap]

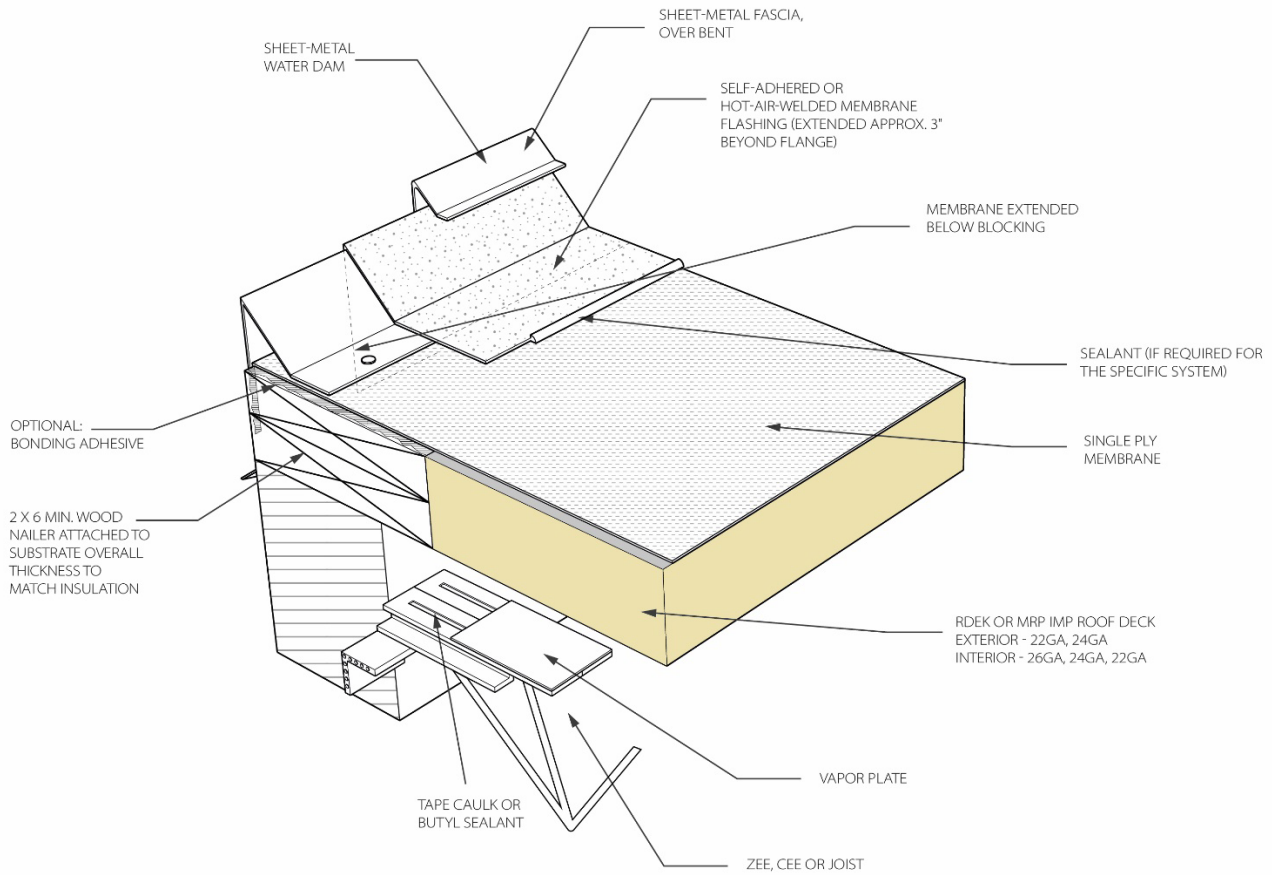

### Base Flashing at Expansion Joint With Metal Cover

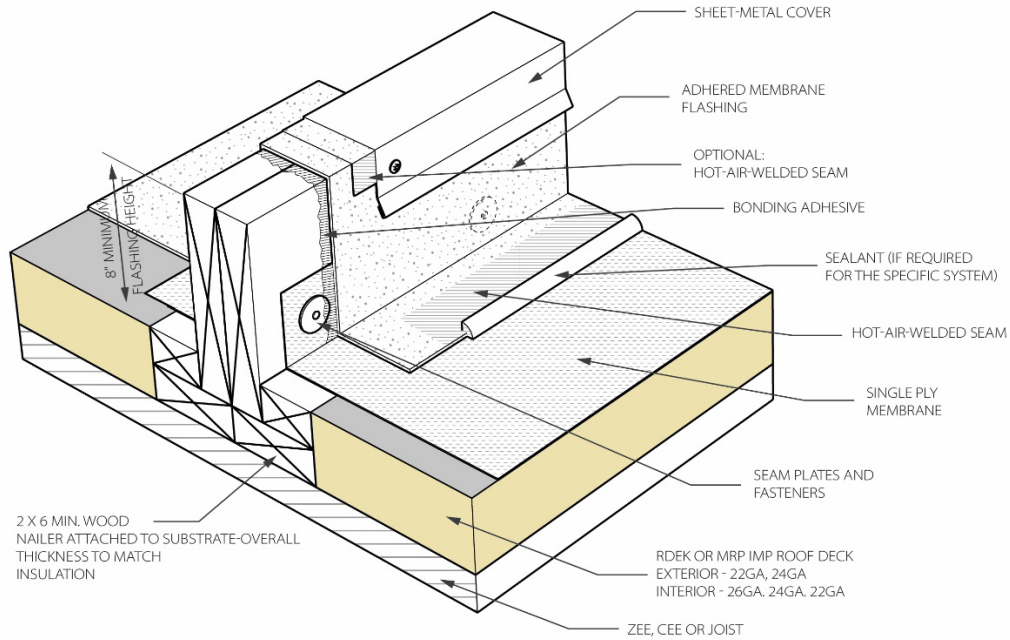

### Base Flashing at Lightweight Equipment Support Curb

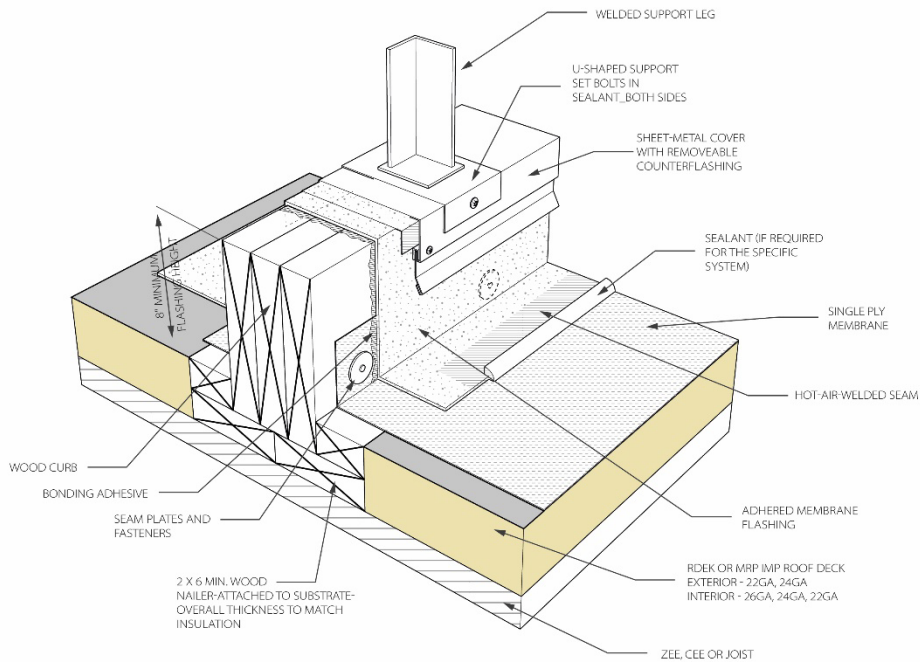

### Equipment Support Stand Leg [Premanufactured Split Pipe Flashing Boot]

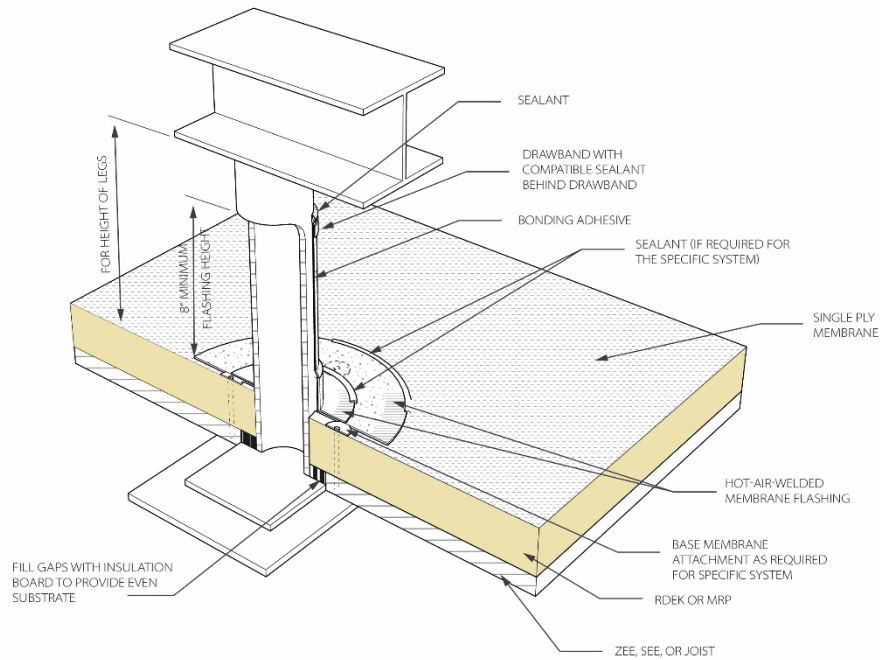

### Equipment Support Stand Leg [Field Wrap]

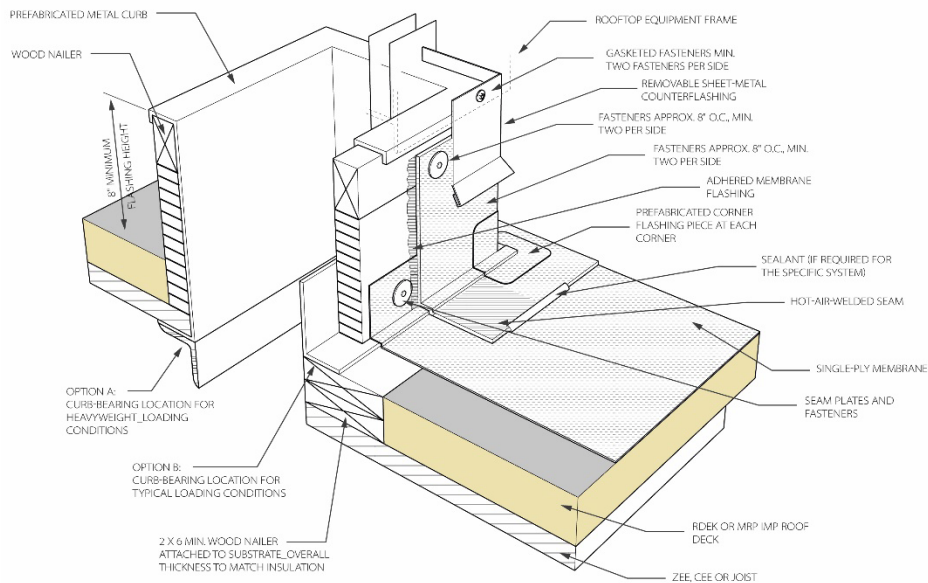

## Base Flashing at Wood Curb

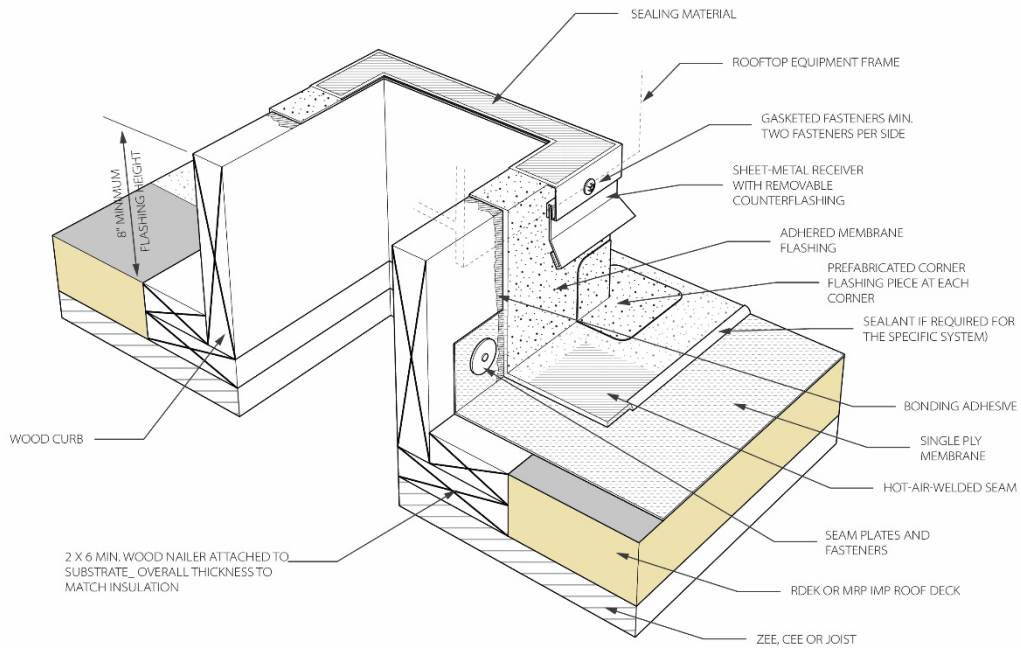

## Base Flashing at Sheet-metal Enclosure for Piping Through Roof Deck

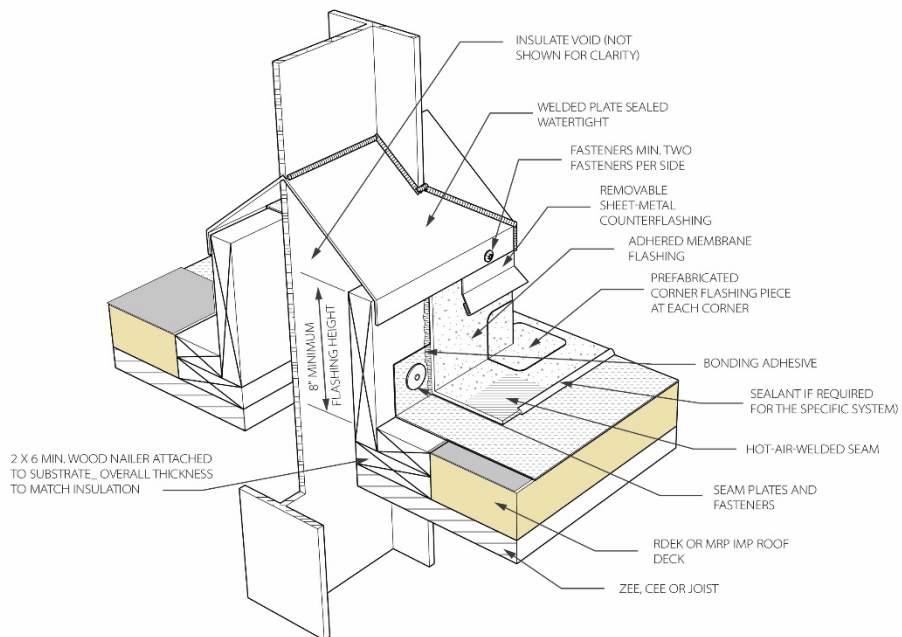



## Pipe Support

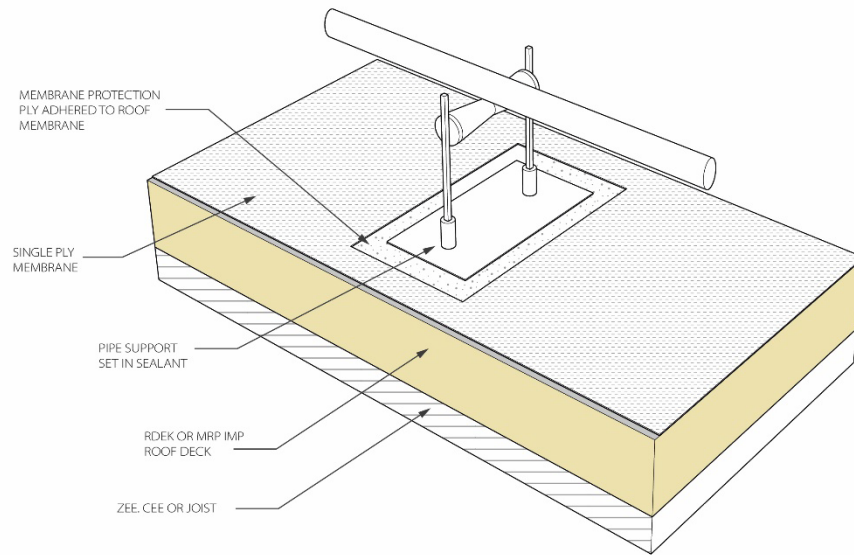

## Cable Penetration

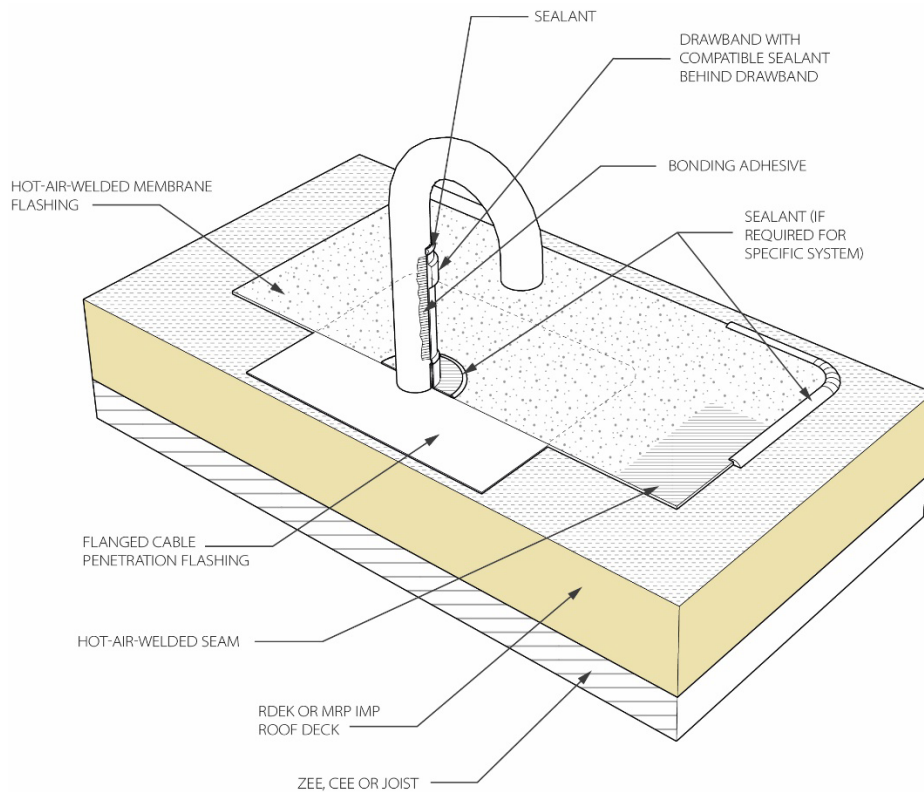

## Lightning Protection Terminal

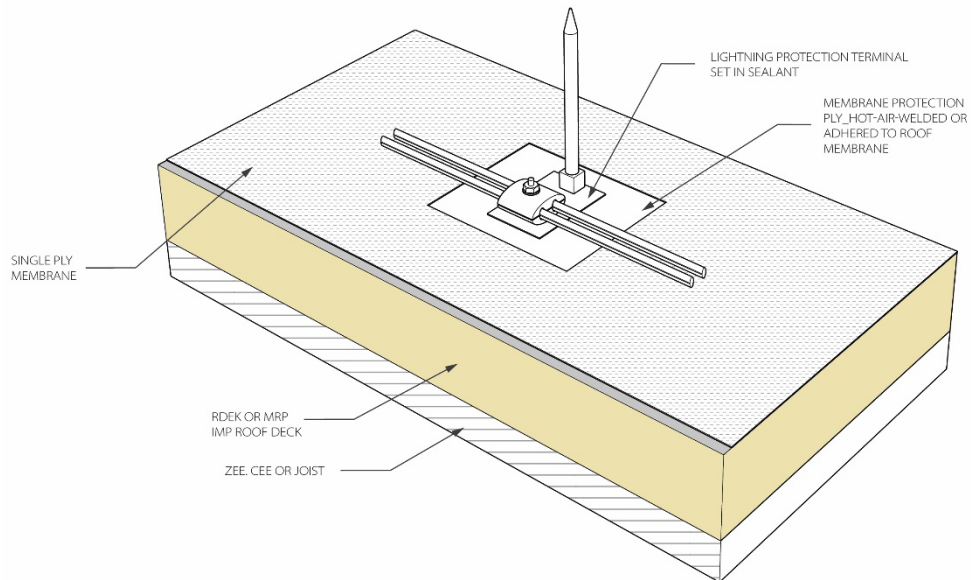

## Roof Drain (Adhered Membrane Roof Systems)

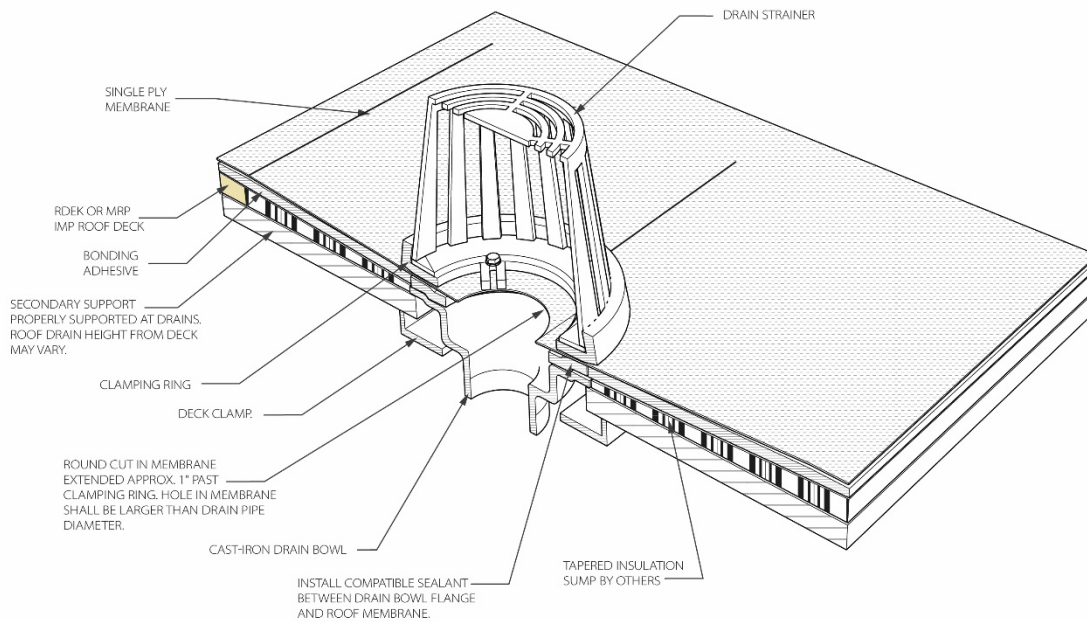

## Base Flashing at Through-wall Scupper

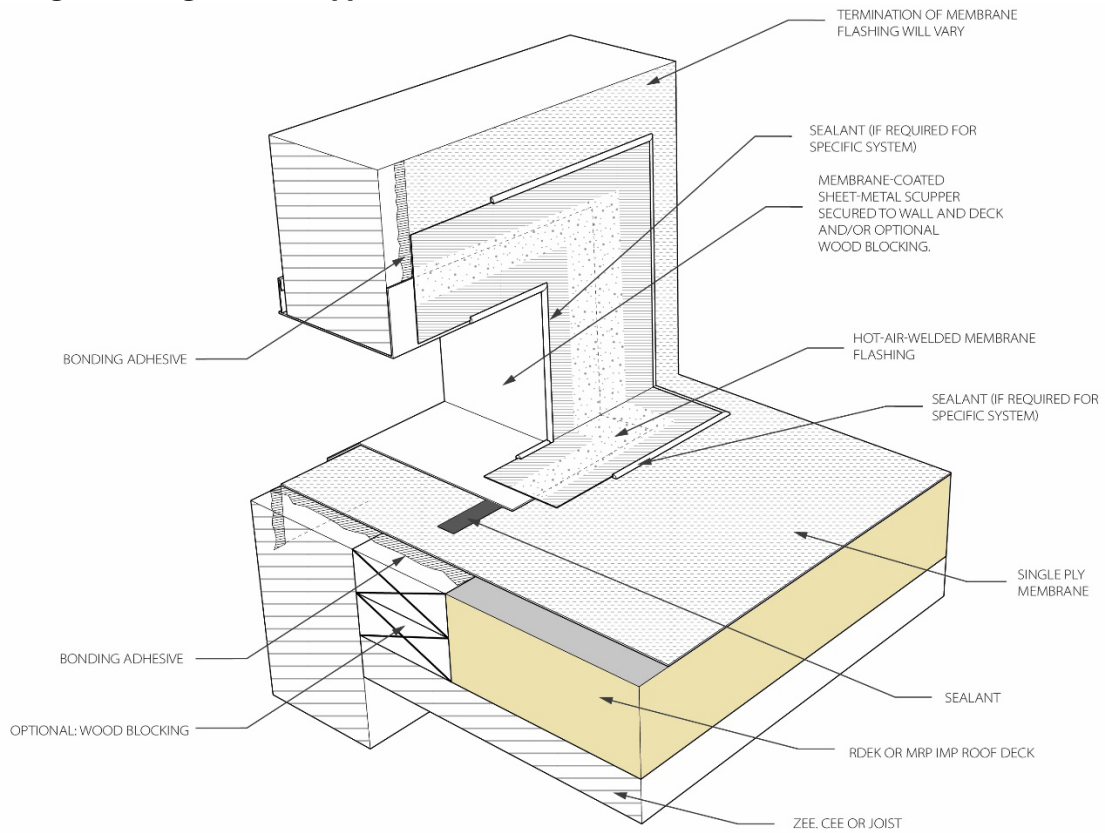



## Open Web Joist Detail

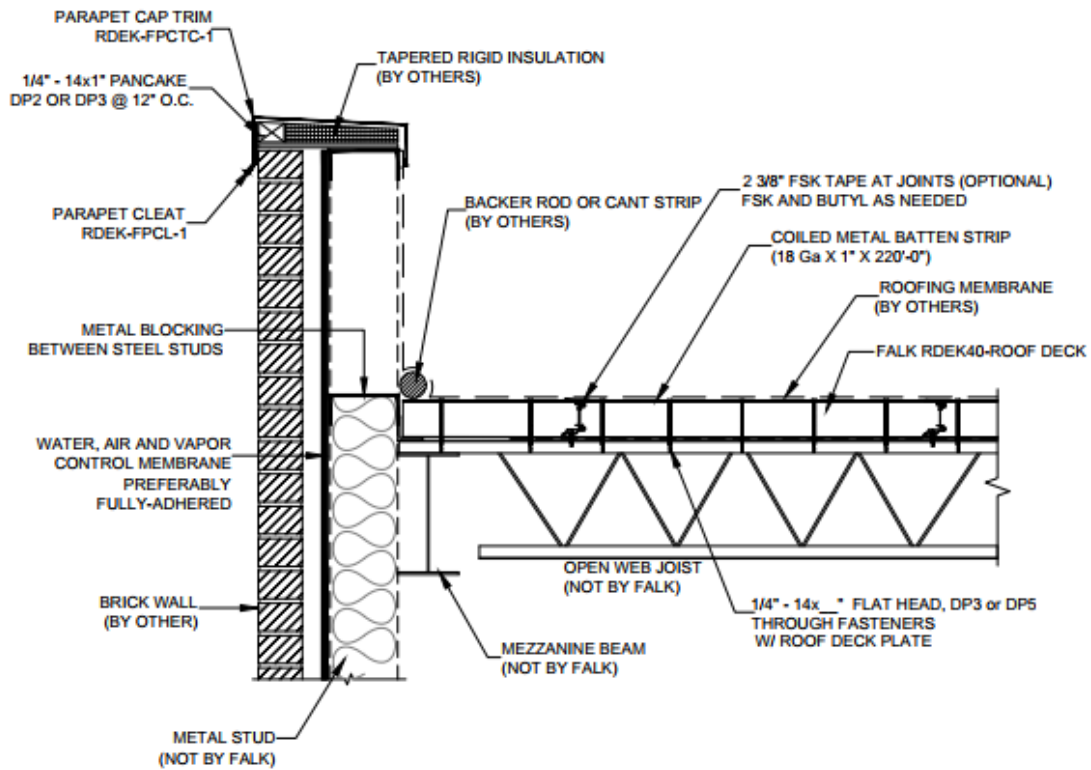

## Joist Edge Detail

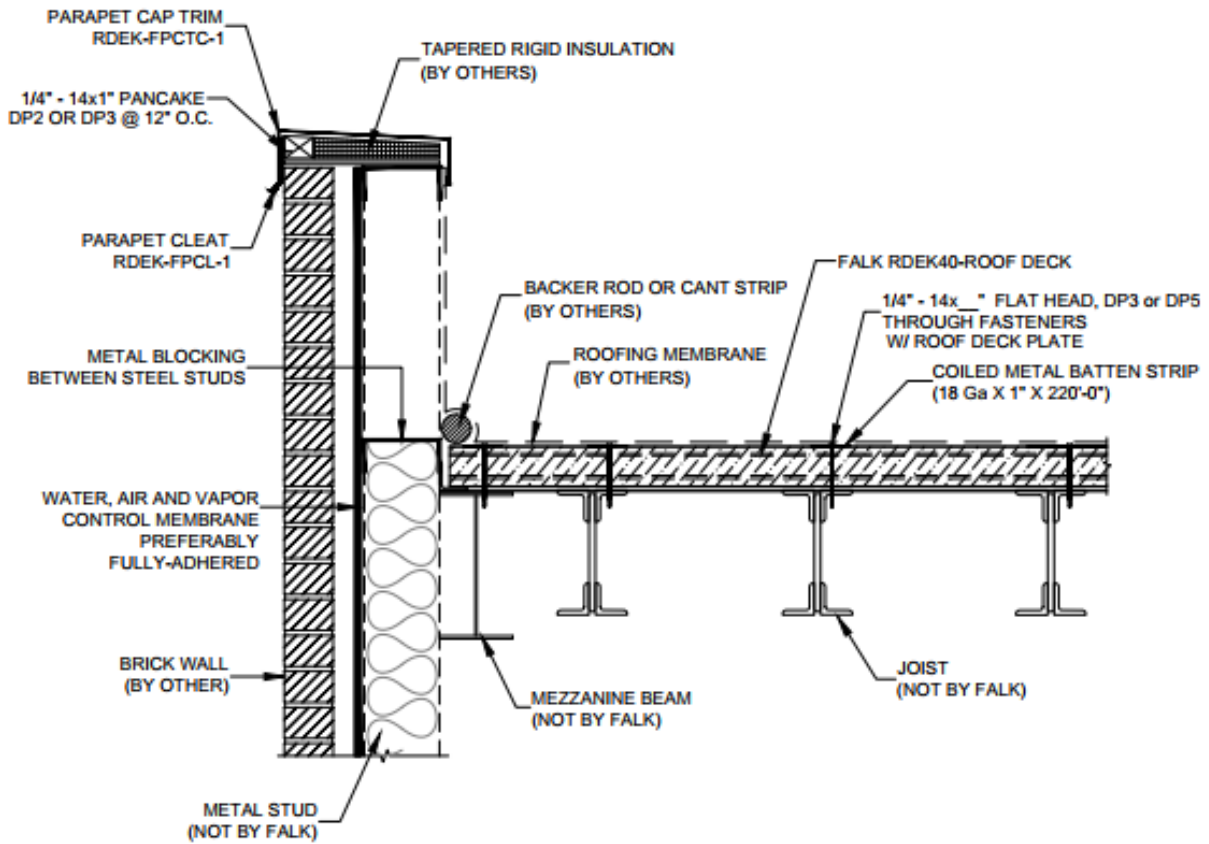

### Fully Adhered with Fastener Assembly - Joist

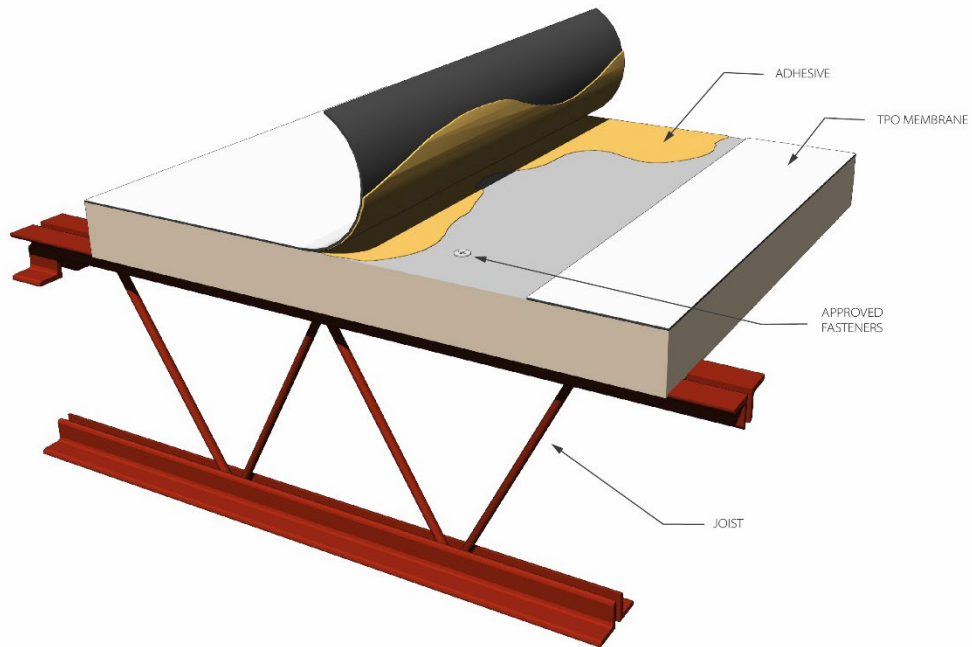

### Fully Adhered with Batten Assembly - Joist

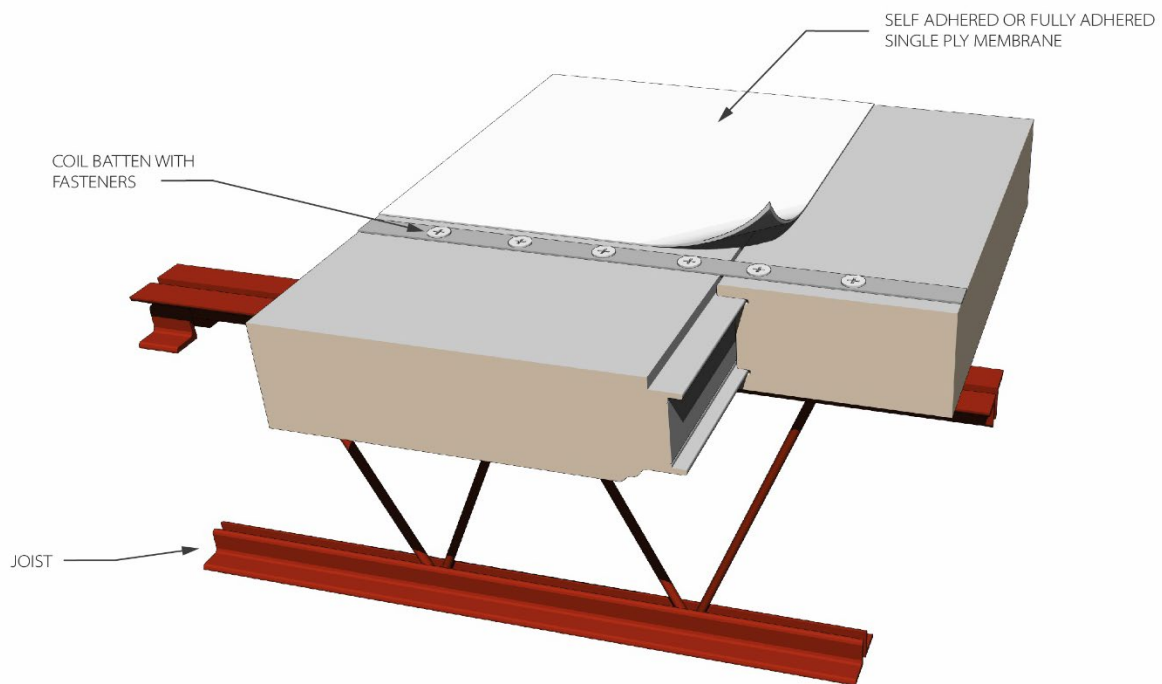

### Fully Adhered with Batten Assembly

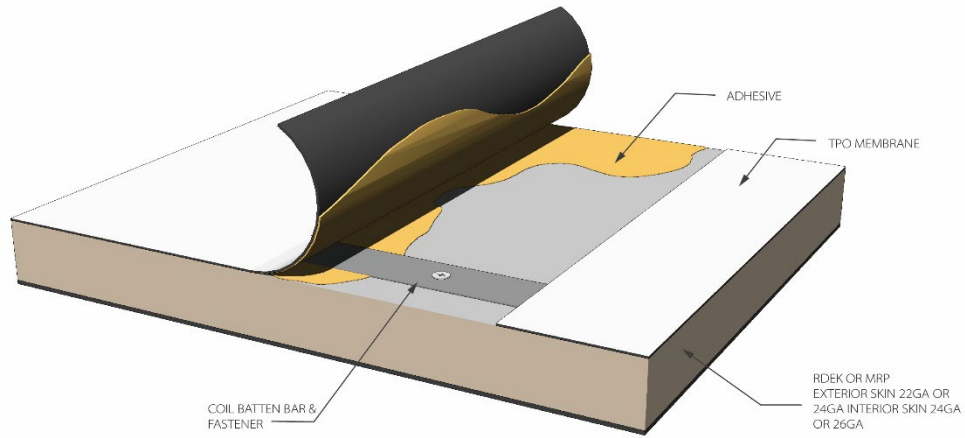

### Fully Adhered with Fastener Assembly

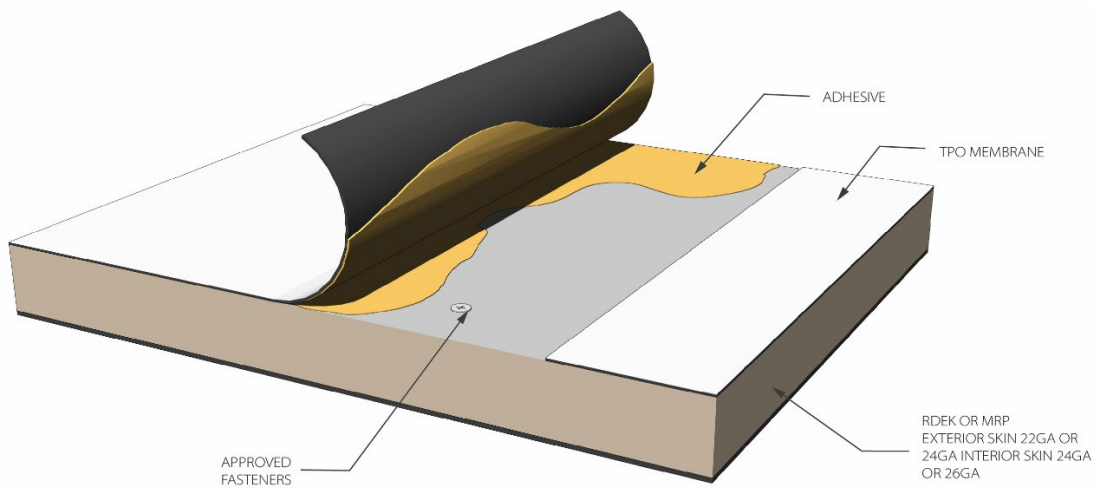



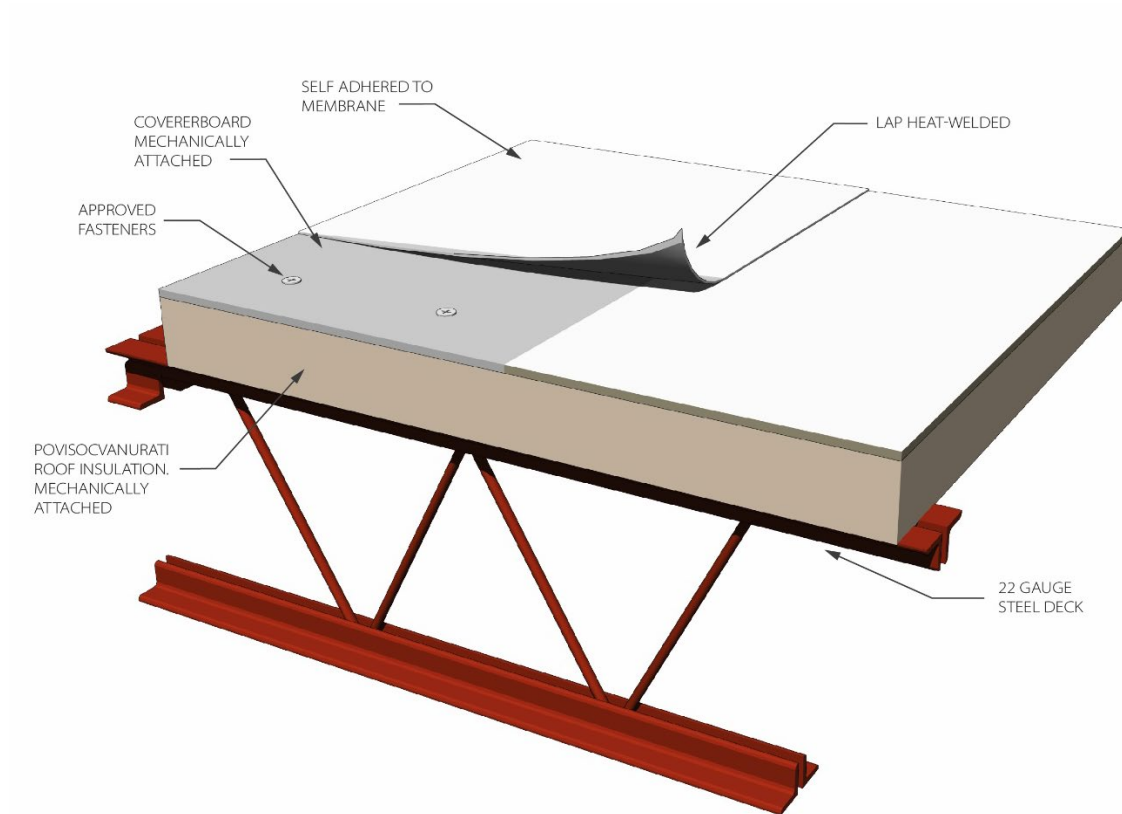

## Self-Adhered with Fastener Assembly



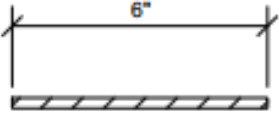
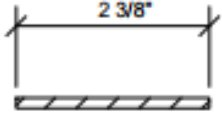

## ACCESSORIES & FASTENERS

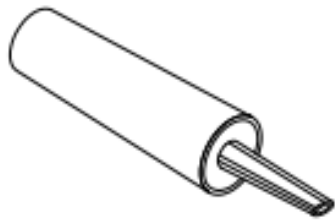
**Accessories-1**

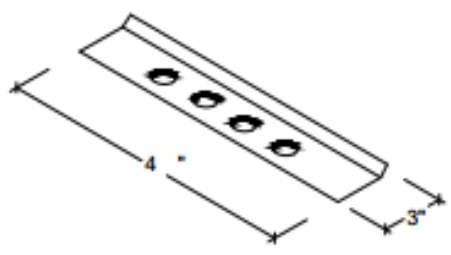
 <p><b>AT END JOINTS TAPE</b> Size: 6" x 150' length</p>	 <p><b>AT SIDELAP JOINTS TAPE</b> Size: 2 3/8" FSK Tape (72MM X 46M)</p>
<p><b>6" 3M Venture Tape FSK Facing Tape</b></p>	<p><b>2 3/8" FSK Tape</b></p>
 <p>Size: 3/4" x 32'-0" length</p>	 <p>Limitation: 46'-0" per Tube (24 Tube Per Case) Specification: Tube caulk (drying) Specification: Butyl tube caulk (Non-Skinning 1/4" bead)</p>
<p><b>Perimeter Flashing Compri Band Foam Tape</b></p>	<p><b>Butyl Caulk Tube</b></p>
 <p>Size: 18 Ga. X 1" X 220' LENGTH</p>	 <p>14 gauge Material: Galvanized</p>
<p><b>COILED METAL BATTEN STRIP</b></p>	<p><b>Panel clips (Pressure Plate)</b></p>

**Fasteners 1**

Roof Stitcher Pro With Washer, #10 x 3/4"  
(Box 250 pcs.)



Flashing screw 'Teks' (COLOR MATCH) SQ #8 x 3/4"  
(Box 500 pcs.)



USE DP3 FOR 16 GA.-12 GA. Steel

Panel screw DP3 Bi-metal #12 - #14 x \_\_\_"  
(Box 100 pcs.)



USE DP5 FOR 1/4" - 1/2" Thick Steel

Panel screw DP5 Bi-metal #12 - #14 x \_\_\_"  
(Box 100 pcs.)



**Fasteners 2**

Panel screw S15 Bi-metal #12 - #14 x \_\_\_  
(Box 100 pcs.)



USE DP2 FOR WOOD FRAMING

Panel screw SS DP2, 1/4 - #14 x \_\_\_  
(Box 100 pcs.)



USE DP3 FOR 16 GA. - 12 GA. Steel  
USE DP5 FOR 1/4" - 1/2" Thick Steel

PANCAKE HEAD THROUGH FASTENER

PANEL THICKNESS	PANCAKE HEAD DP3 OR DP5
3"	1/4" - 14x5" Pancake
4"	1/4" - 14x6" Pancake
5"	1/4" - 14x7" Pancake
6"	1/4" - 14x8" Pancake

1/4" - 14x5" Pancake DP3  
(Box 500 pcs.)



USE DP3 FOR 16 GA. - 12 GA. Steel  
USE DP5 FOR 1/4" - 1/2" Thick Steel

1/4" - 14x1" Pancake DP3  
1/4" - 14x1 5/8" Pancake DP3  
(Box 500 pcs.)

**T-2 Selfdrill Roofscrew, LL Coating, PPH, #14 x 1-1/4"**



Coil Batten Bar

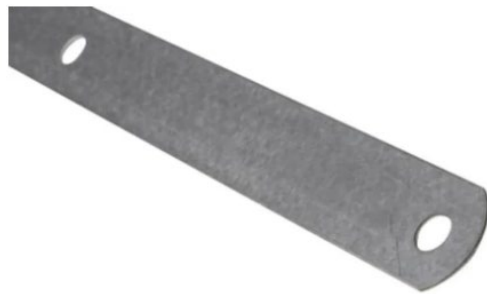

Material Galvalume<sup>®</sup> AZ 55

Corrosion Resistance Meets FM No. 4470 criteria

Length 10' (3 m)

Width 1" (25.4 mm)

Thickness 0.04"/0.05" (1.13 mm/1.29 mm)

Holes .343" (8.71 mm) diameter, at 6" (152 mm) o.c.

(Accommodates All-Purpose, Heavy-Duty, and Concrete Drive Fasteners)

Galvalume<sup>®</sup> is a registered trademark of BIEC International, Inc.



## COMMON FLASHING PROFILES

### Flashings 1

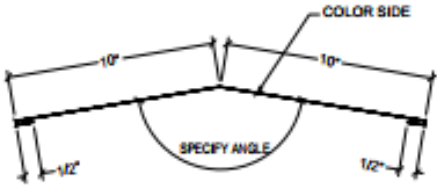
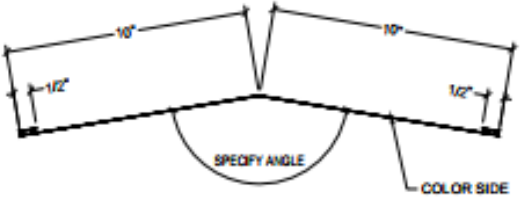
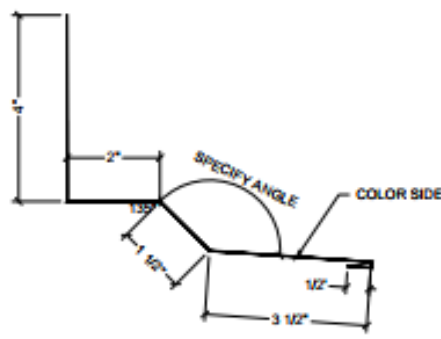
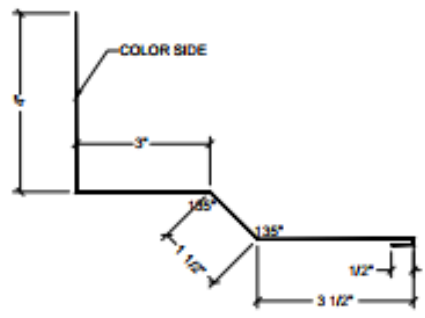
	
<p>EXTERIOR RIDGE FLASHING RDEK-FER1</p>	<p>INTERIOR RIDGE FLASHING RDEK-FIR1</p>
	
<p>PARAPET HIGH EAVE TRANSITION FLASHING RDEK-FPHT1</p>	<p>PARAPET RAKE TRANSITION FLASHING RDEK-FPRT1</p>

ALL TRIM TO BE 10'-0" LONG.

REFERENCE TRIM BOOK FOR ADDITIONAL INFORMATION.

## Flashings 2

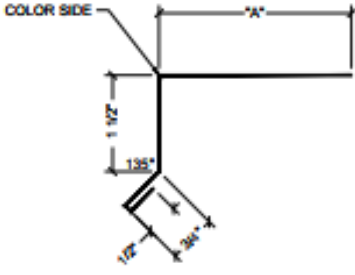
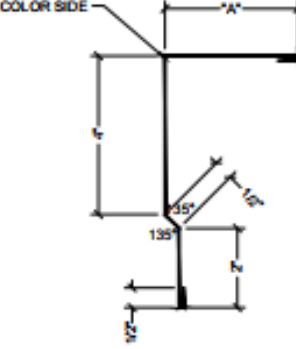
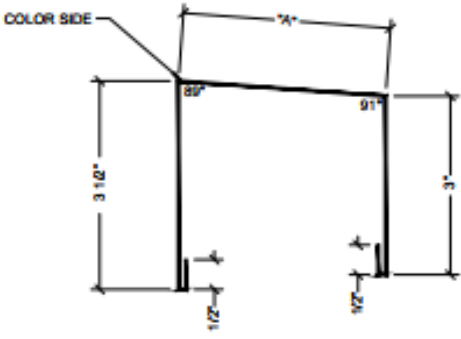
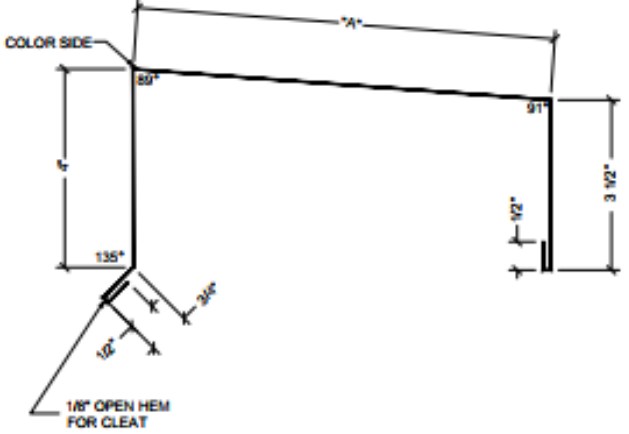
 <table border="1" data-bbox="215 779 820 997"> <thead> <tr> <th>MARK#</th> <th>WALL PANEL THICKNESS</th> <th>DIM. "A"</th> <th>GIRTH</th> </tr> </thead> <tbody> <tr> <td>RDEK - FEF1 - 003</td> <td>3"</td> <td>3"</td> <td>5 3/4"</td> </tr> <tr> <td>RDEK - FEF1 - 004</td> <td>4"</td> <td>4"</td> <td>6 3/4"</td> </tr> <tr> <td>RDEK - FEF1 - 005</td> <td>5"</td> <td>5"</td> <td>7 3/4"</td> </tr> <tr> <td>RDEK - FEF1 - 006</td> <td>6"</td> <td>6"</td> <td>8 3/4"</td> </tr> </tbody> </table>	MARK#	WALL PANEL THICKNESS	DIM. "A"	GIRTH	RDEK - FEF1 - 003	3"	3"	5 3/4"	RDEK - FEF1 - 004	4"	4"	6 3/4"	RDEK - FEF1 - 005	5"	5"	7 3/4"	RDEK - FEF1 - 006	6"	6"	8 3/4"	 <table border="1" data-bbox="873 779 1477 997"> <thead> <tr> <th>MARK#</th> <th>WALL PANEL THICKNESS</th> <th>DIM. "A"</th> <th>GIRTH</th> </tr> </thead> <tbody> <tr> <td>RDEK - FRA1 - 003</td> <td>3"</td> <td>3 3/8"</td> <td>10 3/8"</td> </tr> <tr> <td>RDEK - FRA1 - 004</td> <td>4"</td> <td>4 3/8"</td> <td>11 3/8"</td> </tr> <tr> <td>RDEK - FRA1 - 005</td> <td>5"</td> <td>5 3/8"</td> <td>12 3/8"</td> </tr> <tr> <td>RDEK - FRA1 - 006</td> <td>6"</td> <td>6 3/8"</td> <td>13 3/8"</td> </tr> </tbody> </table>	MARK#	WALL PANEL THICKNESS	DIM. "A"	GIRTH	RDEK - FRA1 - 003	3"	3 3/8"	10 3/8"	RDEK - FRA1 - 004	4"	4 3/8"	11 3/8"	RDEK - FRA1 - 005	5"	5 3/8"	12 3/8"	RDEK - FRA1 - 006	6"	6 3/8"	13 3/8"
MARK#	WALL PANEL THICKNESS	DIM. "A"	GIRTH																																						
RDEK - FEF1 - 003	3"	3"	5 3/4"																																						
RDEK - FEF1 - 004	4"	4"	6 3/4"																																						
RDEK - FEF1 - 005	5"	5"	7 3/4"																																						
RDEK - FEF1 - 006	6"	6"	8 3/4"																																						
MARK#	WALL PANEL THICKNESS	DIM. "A"	GIRTH																																						
RDEK - FRA1 - 003	3"	3 3/8"	10 3/8"																																						
RDEK - FRA1 - 004	4"	4 3/8"	11 3/8"																																						
RDEK - FRA1 - 005	5"	5 3/8"	12 3/8"																																						
RDEK - FRA1 - 006	6"	6 3/8"	13 3/8"																																						
<p>EAVE FLASHING      SEE CHART</p>	<p>RAKE FLASHING      SEE CHART</p>																																								
 <table border="1" data-bbox="215 1486 820 1705"> <thead> <tr> <th>MARK#</th> <th>WALL PANEL THICKNESS</th> <th>DIM. "A"</th> <th>GIRTH</th> </tr> </thead> <tbody> <tr> <td>RDEK - FPCT1 - 003</td> <td>3"</td> <td>3 1/8"</td> <td>10 5/8"</td> </tr> <tr> <td>RDEK - FPCT1 - 004</td> <td>4"</td> <td>4 1/8"</td> <td>11 5/8"</td> </tr> <tr> <td>RDEK - FPCT1 - 005</td> <td>5"</td> <td>5 1/8"</td> <td>12 5/8"</td> </tr> <tr> <td>RDEK - FPCT1 - 006</td> <td>6"</td> <td>6 1/8"</td> <td>13 5/8"</td> </tr> </tbody> </table>	MARK#	WALL PANEL THICKNESS	DIM. "A"	GIRTH	RDEK - FPCT1 - 003	3"	3 1/8"	10 5/8"	RDEK - FPCT1 - 004	4"	4 1/8"	11 5/8"	RDEK - FPCT1 - 005	5"	5 1/8"	12 5/8"	RDEK - FPCT1 - 006	6"	6 1/8"	13 5/8"	 <p>1/8" OPEN HEM FOR CLEAT</p>																				
MARK#	WALL PANEL THICKNESS	DIM. "A"	GIRTH																																						
RDEK - FPCT1 - 003	3"	3 1/8"	10 5/8"																																						
RDEK - FPCT1 - 004	4"	4 1/8"	11 5/8"																																						
RDEK - FPCT1 - 005	5"	5 1/8"	12 5/8"																																						
RDEK - FPCT1 - 006	6"	6 1/8"	13 5/8"																																						
<p>PARAPET PANEL CAP TRIM      SEE CHART</p>	<p>PARAPET CAP TRIM W/ CLEAT      RDEK-FPCTC-1</p>																																								

ALL TRIM TO BE 10'-0" LONG.

REFERENCE TRIM BOOK FOR ADDITIONAL INFORMATION.

### Flashings 3

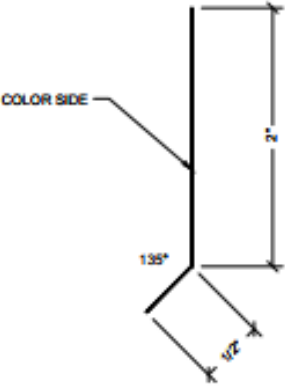
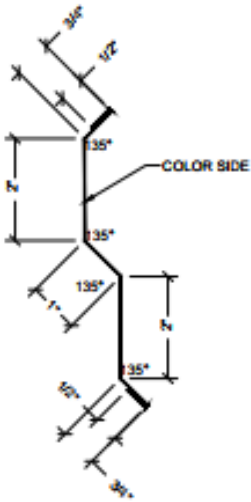
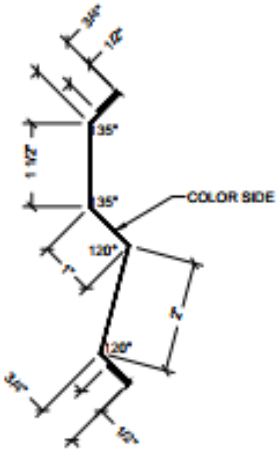
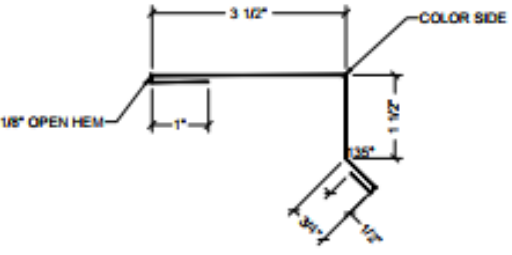
	
<p>PARAPET CLEAT RDEK-FPCL-1</p>	<p>COUNTER FLASHING RDEK-FCU1</p>
	
<p>COUNTER FLASHING RDEK-FCU2</p>	<p>EXPANSION JOINT TRIM RDEK-FEXJ-1</p>

ALL TRIM TO BE 10'-0" LONG.

REFERENCE TRIM BOOK FOR ADDITIONAL INFORMATION.

### Flashings 4

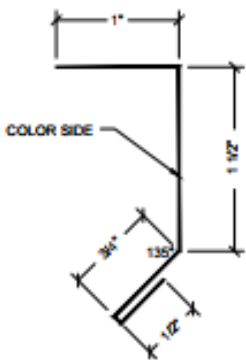
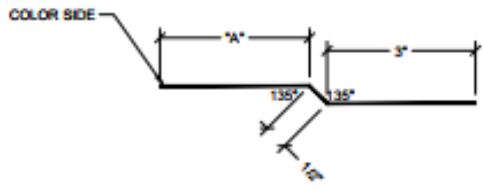
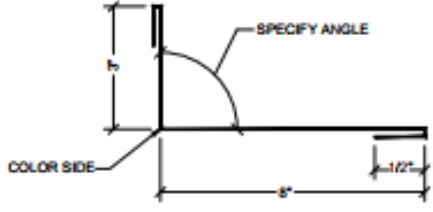
	 <table border="1" data-bbox="860 766 1461 976"> <thead> <tr> <th>MARK#</th> <th>WALL PANEL THICKNESS</th> <th>DIM. "A"</th> <th>GIRTH</th> </tr> </thead> <tbody> <tr> <td>RDEK - FSAM-003</td> <td>3"</td> <td>3 1/8"</td> <td>6 5/8"</td> </tr> <tr> <td>RDEK - FSAM-004</td> <td>4"</td> <td>4 1/8"</td> <td>7 5/8"</td> </tr> <tr> <td>RDEK - FSAM-005</td> <td>5"</td> <td>5 1/8"</td> <td>8 5/8"</td> </tr> <tr> <td>RDEK - FSAM-006</td> <td>6"</td> <td>6 1/8"</td> <td>9 5/8"</td> </tr> </tbody> </table>	MARK#	WALL PANEL THICKNESS	DIM. "A"	GIRTH	RDEK - FSAM-003	3"	3 1/8"	6 5/8"	RDEK - FSAM-004	4"	4 1/8"	7 5/8"	RDEK - FSAM-005	5"	5 1/8"	8 5/8"	RDEK - FSAM-006	6"	6 1/8"	9 5/8"
MARK#	WALL PANEL THICKNESS	DIM. "A"	GIRTH																		
RDEK - FSAM-003	3"	3 1/8"	6 5/8"																		
RDEK - FSAM-004	4"	4 1/8"	7 5/8"																		
RDEK - FSAM-005	5"	5 1/8"	8 5/8"																		
RDEK - FSAM-006	6"	6 1/8"	9 5/8"																		
<p style="text-align: center;">EXPANSION TRIM CLEAT      RDEK-FEXJC-1</p>	<p style="text-align: center;">SELF-ADHERING MEMBRANE FLASHING      SEE CHART</p>																				
																					
<p style="text-align: center;">INTERIOR TRANSITION FLASHING      RDEK-FIT1</p>																					

ALL TRIM TO BE 10'-0" LONG.

REFERENCE TRIM BOOK FOR ADDITIONAL INFORMATION.



**END**